

# RENOGY Portable Power Station

## 1075.2Wh

RPS1600AA

VERSION A0  
October 20, 2025

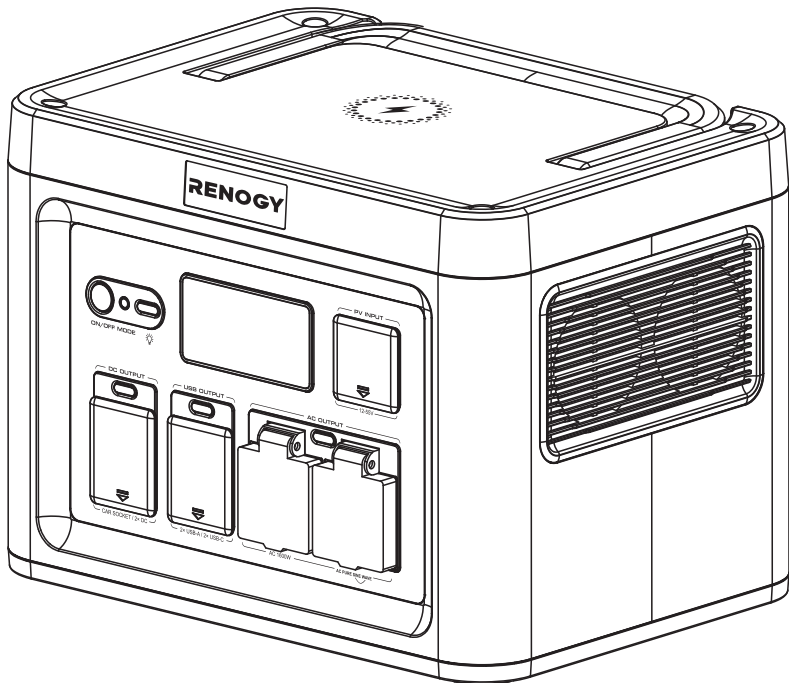

# USER MANUAL

## Before Getting Started

The user manual provides important operation and maintenance instructions for **RENOGY RPS1600AA Series high quality power station** .

Read the user manual carefully before operation and save it for future reference. Failure to observe the instructions or precautions in the user manual can result in electrical shock, serious injury, or death, or can damage the battery, potentially rendering it inoperable.

- Renogy ensures the accuracy, sufficiency, and the applicability of information in the user manual at the time of printing due to continual product improvements that may occur.
- Renogy assumes no responsibility or liability for personal and property losses, whether directly and indirectly, caused by the user's failure to install and use the product in compliance with the user manual.
- Renogy is not responsible or liable for any failure, damage, or injury resulting from repair attempts by unqualified personnel, improper installation, or inappropriate operation.
- The illustrations in the user manual are for demonstration purposes only. Details may appear slightly different depending on product revision and market region.
- Renogy reserves the right to change the information in the user manual without notice. For the latest user manual, visit [renogy.com](https://www.renogy.com).

## Disclaimer

RENOGY **RPS1600AA Series high quality power station** User Manual © 2025 Renogy. All rights reserved.

RENOGY and **RENOGY** are registered trademarks of Renogy.

- All information in the user manual is subject to copyright and other intellectual property rights of Renogy and its licensors. The user manual may not be modified, reproduced, or copied, in whole or in part, without the prior written permissions of Renogy and its licensors.
- The registered trademarks in the user manual are the property of Renogy. The unauthorized use of the trademarks is strictly prohibited.

## Online User Manual

Scan the QR code or visit [renogy.com](https://www.renogy.com) to view the user manual.





# Table of Contents



<b>Symbols Used</b> .....	1
<b>Symbols on Product</b> .....	1
<b>Introduction</b> .....	1
<b>SKU</b> .....	1
<b>Safety Instructions</b> .....	1
<b>What's In the Box?</b> .....	2
<b>Get to Know Power Station RPS1600AA Series</b> .....	3
<b>Dimensions</b> .....	4
<b>Button Description</b> .....	4
<b>LCD Display</b> .....	6
<b>List of Fault Codes</b> .....	7
<b>Charging</b> .....	8
<b>Operation</b> .....	10
<b>Transport Instructions For Dangerous Goods</b> .....	11
<b>Monitoring</b> .....	12
<b>Troubleshooting</b> .....	13
<b>Specifications</b> .....	13
General.....	13
Operation Parameters.....	13
<b>PRODUCT MAINTENANCE</b> .....	14
<b>WARRANTY</b> .....	14
<b>Renogy Support</b> .....	15
<b>Battery Recycling</b> .....	16

## Symbols Used

The following symbols are used throughout the user manual to highlight important information.

-  **WARNING:** Indicates a potentially dangerous condition which could result in injury or death.
-  **CAUTION:** Indicates a critical procedure for safe and proper installation and operation.
-  **NOTE:** Indicates an important step or tip for optimal performance.

## Symbols on Product

Symbol	Description	Symbol	Description
	Regulatory compliance mark		Do not dispose of the product together with household waste.
	Lithium-ion Battery		

## Introduction

RPS1600AA Series features a high capacity and high safety battery pack.

It is very convenient for emergency off-grid demand such as sudden power failure, snowstorm or hurricane, outdoor tourism, outdoor operation, RV power supply, etc. There is perfect performance with great power output up to 1600W, fast charging, high capacity and long cycle life

## SKU

RENOGY RPS1600AA Series	RPS1600AA
-------------------------	-----------

## Safety Instructions

- DO NOT disassemble, repair or modify the unit or the battery.
- DO NOT place the unit close to or in a fire or expose it to heat.
- Keep out of direct sunlight.
- DO NOT charge, use or store the unit in a bathroom or in an area exposed to rain or moisture. Only use the output socket to power external devices.
- Never connect the output to mains power under any circumstances.
- DO NOT touch the unit or the plug in points if your hands are wet.
-  ● DO NOT connect any metallic objects to the AC input or output.
- DO NOT rub your eyes if fluid from inside the unit should get in your eyes.
- DO NOT dispose the unit together with household waste.
- DO NOT use any inappropriate power cords.
- DO NOT operate the unit above the specified input voltage.
- DO NOT use the unit if it is not functioning correct.
- DO NOT move the unit if it is recharging or in use.

- Use and store the unit only in a clean and dry environment. Do not operate and store in dust and wet environment.
- Check the unit prior to every use. Do not use the unit if it is damaged or broken.
- DO NOT use the unit if the power cord is damaged or broken. Keep the unit away from children.
- DO NOT let children use the power supply unit. Keep this product away from pets.
- DO NOT use or store the unit in an area or environment with high temperature.
- Should fluid from inside of the unit come in contact with your skin or clothing, wash the affected areas with tap water. In a storm, unplug the power cord from the socket.
- DO NOT charge the device through a power system other than the rated voltage.
- DO NOT place the unit on its side or upside down while in use or storage.
- DO NOT use accessories for other usage.



- If rust, peculiar odors, overheating, or other abnormal circumstances are observed, stop using the unit immediately and contact the dealer or our customer service center.
- The unit complies with all legal requirements for transport of dangerous goods.
- Make sure that the unit is properly secured when transporting it in a motor vehicle.
- Only charge, use and store the unit within an ambient temperature of 0 to 40°C (32 ~ 104°F).
- Switch the unit off immediately if it has accidentally fallen, was dropped or was exposed to vibrations.
- Once the unit is fully charged, unplug the AC charging cable. We are not liable for any damage caused by using different brand charging cables.
- Use of different cables will void the products warranty and may cause damage or serious bodily injury.



- Battery life may be reduced or become nonfunctional if not properly maintained.
- Fully charge and discharge at least every 3 months to ensure battery life.
- Do not store battery with less than 50% charge.



## What's In the Box?

RENOGY Portable Power Station

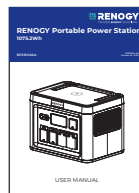
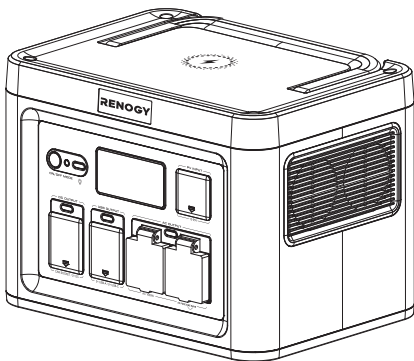

User Manual × 1

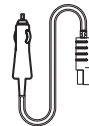

12 V Car Anderson Cable × 1

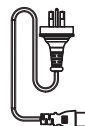

AC Charging Cable × 1

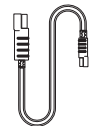

Anderson Connector Adapter

**i** Make sure that all accessories are complete and free of any signs of damage.

## Get to Know Power Station RPS1600AA Series

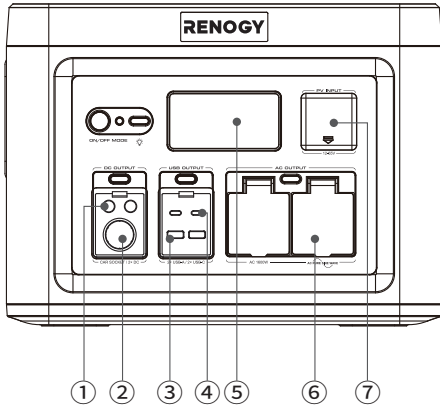

① DC Output
② Cigarette Lighter Socket Output
③ USB-A Output
④ USB-C Output
⑤ LCD Screen Display
⑥ AC Output x 2
⑦ PV Input

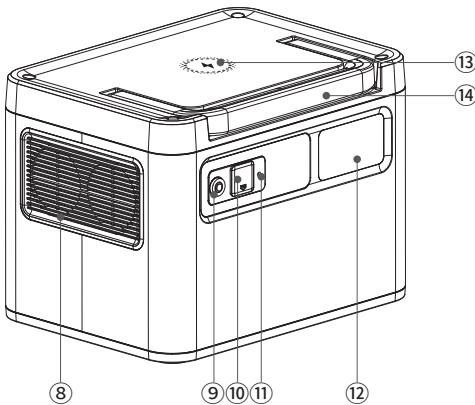



⑧ Air Intake Vent with Cooling Fan
⑨ OLP Reset
⑩ AC Input
⑪ Grounding Port
⑫ LED Light
⑬ Wireless Charge
⑭ Folding Handle

**i** If the battery with low power, please charges it before use.

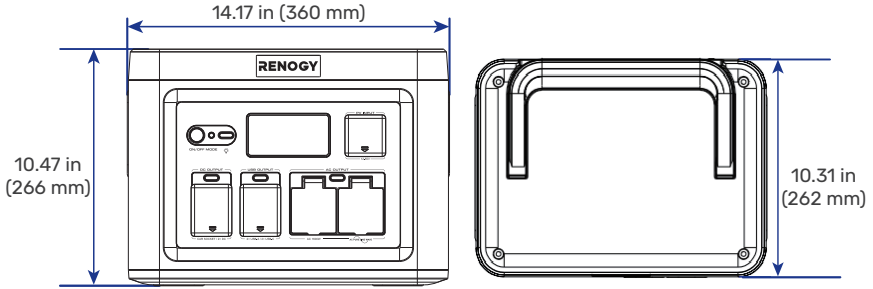
## Dimensions



 **Weight** 34.4 lbs / 15.6 kg

 Dimension tolerance:  $\pm 0.2$  in (0.5 mm)

## Button Description

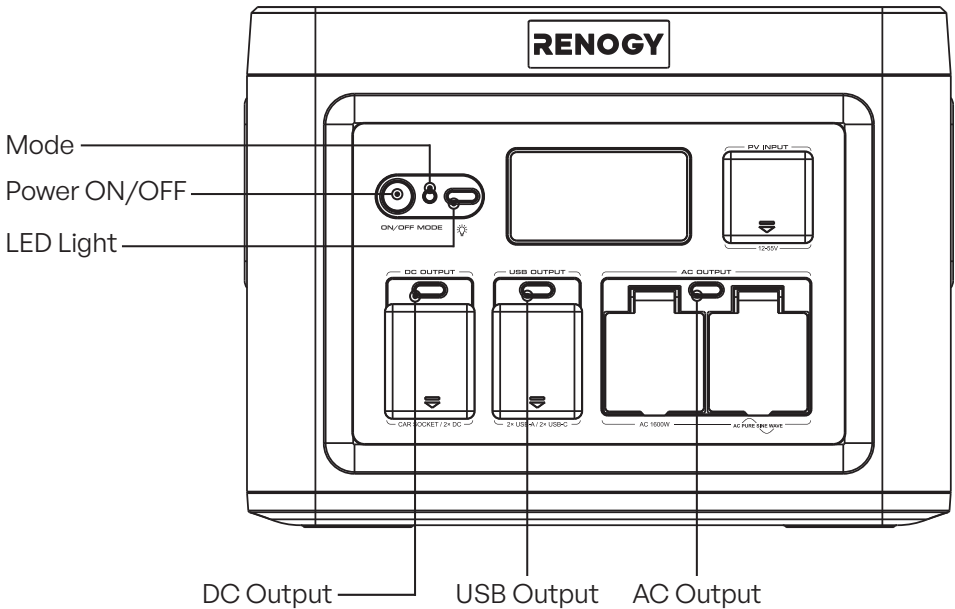

Item	Description
Mode	<p>The default <b>Bluetooth</b> is enabled when the device is power on. Short press the button to turn <b>Bluetooth</b> off.</p> <p><b>Fast/ Slow Charging Mode:</b></p> <ol style="list-style-type: none"> <li>1. Press and hold the button for 3 seconds to turn the mode on. (<b>Bluetooth</b> must be off)</li> <li>2. Press and hold the button for 3 seconds to turn the mode off. (<b>Bluetooth</b> must be off)</li> </ol>
Power ON/OFF	Press the button to turn on or turn off the equipment.
LED Light	<p>The LED light function works regardless of whether the <b>Power ON/OFF</b> button is activated. To operate:</p> <ol style="list-style-type: none"> <li>1. Short press once, and the light brightness is 50%.</li> <li>2. Short press twice, and the light brightness is 100%.</li> <li>3. Short press three times, and the light enter the flashing mode.</li> <li>4. Short press four times, and the light enters the SOS mode.</li> <li>5. Short press five times, and the light is turned off.</li> </ol> <p>When press and hold the button for 1.5 seconds at any time, the LED light turns off.</p>
DC Output	Before pressing the button to activate the DC output, make sure the equipment is powered on. Press the button again to stop the DC output.
USB Output	<p>Before pressing the button to activate the USB output, make sure the equipment is powered on. Press the button again to stop the USB output.</p> <p><b>Note:</b> Devices supports different USB-C protocols. If USB-C port is not working, please check whether the unit is charged.</p>
AC Output	Before pressing the button to activate the AC output, make sure the equipment is powered on. Press the button again to stop the AC output.

## LCD Display

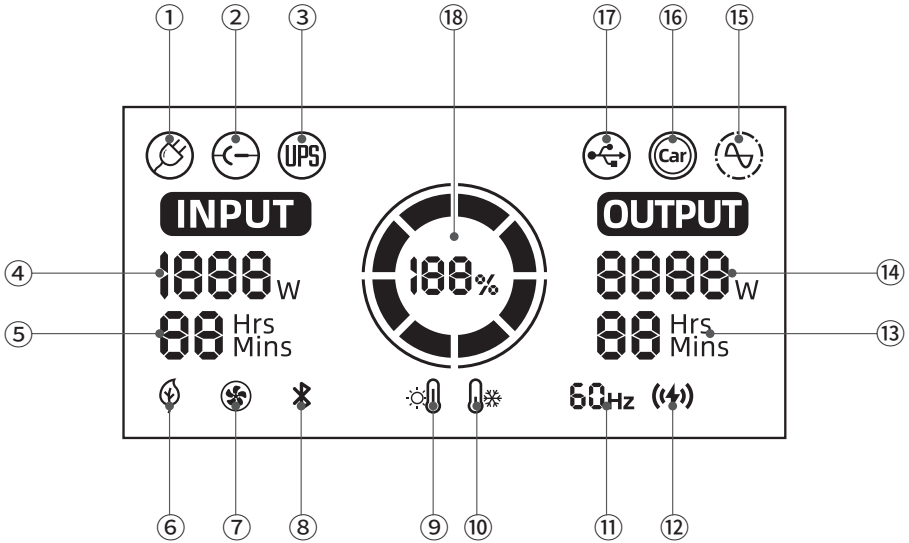

Number	Item	Description
1	AC Input	When the AC charging cable is inserted, this label is displayed on the LCD.
2	DC Input	When the DC DC/SOLAR PV charging cable is inserted, this label is displayed on the LCD.
3	UPS Mode	When the device is in the AC charging state and the AC output is turned on, the UPS mode automatically starts and this label is displayed on the LCD
4	Input Power	When charging, the display displays <b>INPUT</b> and charging power.
5	Input Time	When charging, the display shows full remaining time.
6	Quick Charge Switching	When the AC charging mode is used, the label is displayed when the charging mode is switched to slow charge.
7	Fan Start Cooling Status	When the fan is running, this label is displayed on the LCD.
8	IOT	When Bluetooth connection is successful, this icon stays on and the icon flashes during connection.
9	High Temperature Alarm	When the inverter or battery pack temperature is too high, this label is displayed on the LCD.
10	Low Temperature Alarm	When the temperature of the inverter or battery pack is too low, this label is displayed on the LCD
11	AC Output Frequency	When the AC switch is turned on, the display displays <b>OUTPUT</b> and the icon.
12	Wireless Charge	When the wireless charge output is active, this icon is displayed on the LCD.

Number	Item	Description
13	Output Time	In the output state, the screen displays the remaining output time.
14	Output Power	Displays the total used power of DC output, USB-A, USB-C, and AC output. <b>Note:</b> This value can be adjusted multiple times as the energy consumption of the connected device changes. This is evident when the port is initially activated using a connected device.
15	AC Outputs	After the AC output switch is turned on, the icon lights up and displays the total ac output power, current remaining time, and current frequency
16	DC Output	When the DC output switch is turned on, the icon lights up and displays the total DC output power and the current remaining time.
17	USB Output	When the <b>USB Output</b> is turned on, the icon lights up and displays the total USB output power and the current remaining time.
18	Battery Level Indicator	Displays the current battery level in the form of energy circle + percentage. The main switch is turned on and the battery quantity is displayed. During the charging process, the energy circle is displayed dynamically.

## List of Fault Codes

Fault Code	Symptom	Solutions
E01	Battery over voltage	Please disconnect the charging cable and stop charging
E02	Battery under voltage	Please disconnect the output and charge the device
E03	Inverter overheating	Please disconnect the output and wait 1-2 hours before operation
E04	Abnormal input voltage	Please disconnect the charging cable
E05	Abnormal grid frequency	Please disconnect the charging cable
E06	Output voltage anomaly	Please contact customer service center
E07	Output short circuit	Please disconnect the output and check the electrical equipment
E08	Output overload	Please disconnect output
E09	Inverter failure	Please contact customer service center

**i** When the DC load is abnormal, the system will automatically turn off the output and will not show the fault code. Please disconnect the output and check the electrical equipment then try again. When the USB load is abnormal, the corresponding output power will be zero and the system will not show the fault code. Please disconnect the outputs and check the electrical equipment, then try again.

# Charging

## Re-charging Time

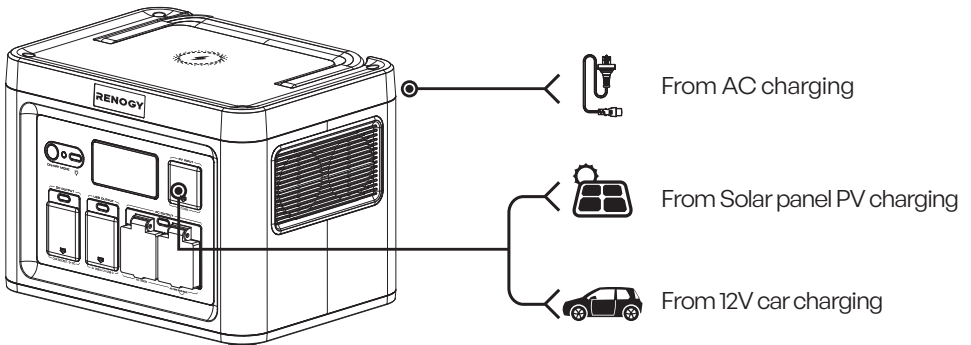

**i** If the battery with low power, charge it before use.

## AC Charging

Use the AC charging cable we provided to charge the device. When LCD showing battery power reached 100%, it means that battery has been full charged and input power will turn off in minutes.

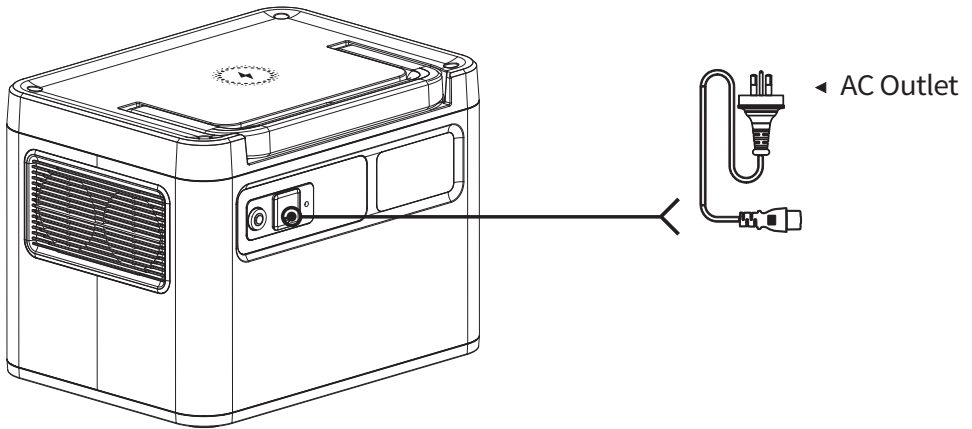

**i** When the device is charging, if the AC input current is more than 6.5A, the device will be overloaded, a fault code **E16** will be showed on the LCD, the output will be shut off after 10 seconds. Please disconnect the output load then press the AC switch once to clear it.

### ■ 12V Car Charging

Use our car charging cable to charge. When the LCD shows that the battery power is 100%, it means that the battery is fully charged.

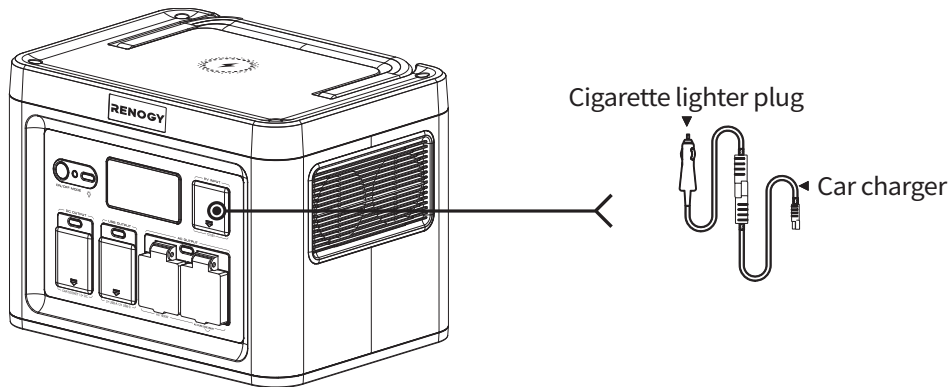

**⚠** Do not charge the product with solar PV input and car port at the same time!

### ■ Solar PV Charging

Support 100W~400W solar panel charging, the charging time is determined by the sunlight intensity. Please place as many solar panels in direct sunlight as possible.

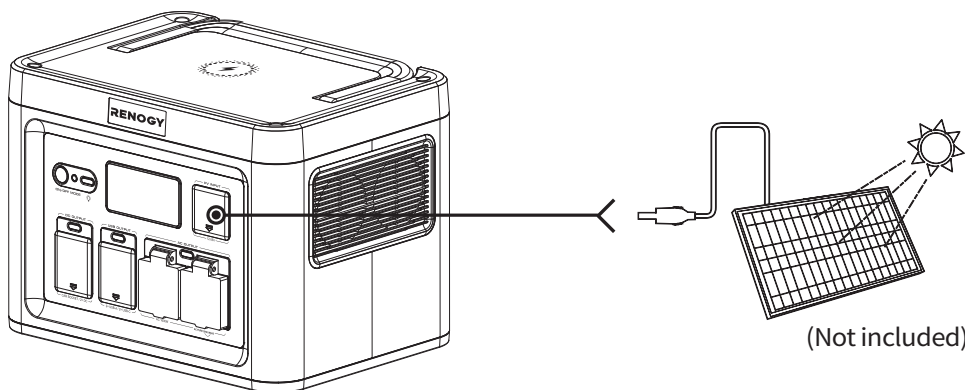

**⚠** The total open circuit voltage of solar modules after series-parallel connection should not exceed the specified voltage! please confirm the same voltage specification.

# Operation

## ■ Power Output Attention

Press output switch to select the desired outlet type. The output port must press the corresponding button to activate the port. When activated, the LCD display will turn on and provide detailed information about the charging output. When no output is activated, the LCD screen will automatically turn off.

## ■ Overload Condition

If the AC and USB outputs are overloaded or short-circuited, the device will automatically turn off the output power. The code **E07** will be displayed on the LCD screen.

If the DC output is overloaded or short-circuited, the device will automatically turn off the output power. The code **E08** will be displayed on the LCD screen

## ■ Discharging

Press the **Power On/Off** button for 1 seconds to turn on the device. Press the **Power On/Off** button for 3 seconds to turn off the device. The device uses an advanced battery management system that allows it to charge the connected device through AC or DC output or USB output.

## ■ How to switch frequency?

The device can intelligently identify the frequency of voltage when charging, and can automatically set the frequency, so please charge before using. After plugging in the charging cable, the display will show the frequency of current grid voltage if it displays **50**, it is 50Hz, if it displays **60**, it is 60Hz.

You can also manually set and change the voltage frequency. Before turning on the power station, confirm whether the the connected equipment requires **50 Hz** or **60 Hz**.

Press the **Power On/Off** button for 1 seconds to turn on the device. If **50** is displayed on the LCD, it means that the operating frequency of the power station is 50 Hz. If **60** is displayed on the LCD screen, it means 60 Hz.

If the frequency displayed on the LCD display does not match the frequency of the local power grid, you must change the frequency according to the following steps:

Step 1: Press and hold the button **Power On/Off** for 3 seconds to power off (the LCD display screen will turn off).

Step 2: Keep pressing the button **AC On/Off** with your right finger first and then press and hold the button **Power On/Off** for 1 seconds with your left finger.

Step 3: Release the both fingers off the buttons. You see the frequency.

**NOTE:** The device might stop charging due to unstable input frequency. This is a normal safety function. Please disconnect the input power and restart the device, then confirm that the correct frequency (50 Hz or 60 Hz) is displayed before use.

## ■ Cooling Fan

The equipment is designed with an internal cooling fan to ensure that the product runs within the proper temperature range. When the device experiences a high output load, it will automatically turn on the fan. During discharging and charging, the fan may run intermittently to keep the internal temperature within the operating range. When the AC circuit is activated, the fan is likely to start to ensure normal operation.



## ■ Power Saving Sleep Mode

1. No charging (AC input + PV), no discharging (DC + USB + AC). When charging is not connected and only the main switch is turned on: sleep after 5 minutes.
2. Any charging is connected (regardless of whether there is power), and it does not sleep.
3. Without any charging input, USB <5W, DC <5W, AC <25W, three conditions are met at the same time, and sleep after a delay of 8 hours.

4. The self-consumption of whole machine is less than 5mA after shutting down all switch and sleeping.
5. Please turn off the main power switch during transportation or it will not be used for a long time. Self-consumption after switching off is less than or equal to 200 $\mu$ A.

### ■ Intelligent Load (Smart Load)

The device supports Intelligent Load operation for resistive devices up to 2000 W. If the load exceeds this limit, the unit will automatically enter protection mode and stop output.

-  Connect only devices within the 2000 W limit for safe, stable operation.
-  Intelligent Load is disabled while charging via AC input.
-  Protection triggering is normal; the device will resume output once the load is reduced.

### ■ Equipment Cleaning

- Make sure that the device is disconnected from all input power and output devices.
- Wipe with a clean, dry, non-soft cotton cloth.
- Remove all any foreign objects, dirt or other obstructions on the vents on both sides.
- While cleaning foreign objects in the side vents, do not allow debris, dirt or other blockage to enters the equipment.
- Do not use corrosive cleaners or solvents.
- Do not use compressed air to clean the side cooling vents, as it will cause foreign particles to enter the interior and cause a short circuit.

-  To avoid the risk of electric shock, do not use metal objects to clean the ports.

### ■ Storage

If it will be stored for more than 1 month, please charge it to 50% capacity and keep it indoors, at normal temperature, and the maximum storage time shall not exceed 6 months. Please keep it away from direct sunlight. Excessive temperature will lead to reduced service life, overheating and fire.

Extremely cold conditions below the specified storage range can also impair the performance and service life of the equipment. Please keep away from corrosive chemicals and gases.

After taking it out of storage, perform a visual inspection to ensure that the appearance of the equipment and all accessories are qualified. Check the vents on the intake and exhaust sides to make sure they are free of foreign objects.

## Transport Instructions For Dangerous Goods



Not permitted on aircraft.



Avoid dropping.



Do not disassemble.



Avoid extreme temperature.



To preserve the battery lifespans, use and recharge at least once every 3 months.



Use an original or certified charger or cable.



Not waterproof. Do not expose to liquids.



Please dispose of batteries and electronic goods in accordance with local regulations.

- i** The RPS1600AA Series power station meets all legal requirements for the transportation of dangerous goods. The capacity of the lithium battery pack exceeds 100Wh. According to international standards, if the power station is transported by air, it must be transported in accordance with IATA standard packaging. The instructions and labeling requirements of the International Air Transport Association and related declarations must be completed.

## Monitoring

Depending on the specific application, the battery can establish either short-range or long-range communication connections with monitoring devices. These monitoring devices facilitate real-time monitoring, programming, and complete system management, offering comprehensive control and enhanced flexibility.

You can monitor the performance of the battery through the Renogy app (free of charge).

- i** Ensure the Bluetooth of your phone is turned on.
- i** The version of the Renogy app might have been updated. Illustrations in the user manual are for reference only. Follow the instructions based on the current app version.
- i** To ensure optimal system performance, keep the phone within 10 feet (3 m) of the power station.

**Step 1:** To ensure the optimal device compatibility, download and log into the latest Renogy app.

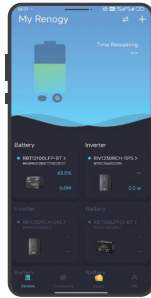

**Step 2:** Pair the power station with the Renogy app. Monitor the power station parameters via the app.

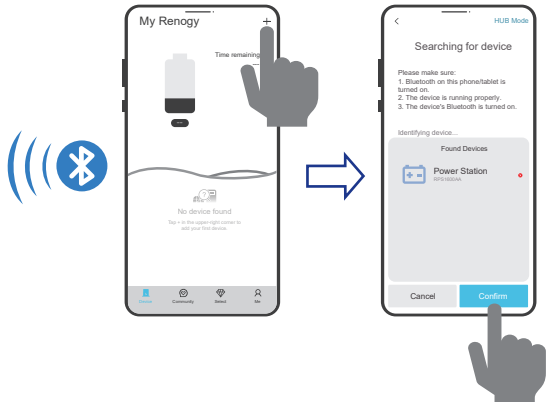
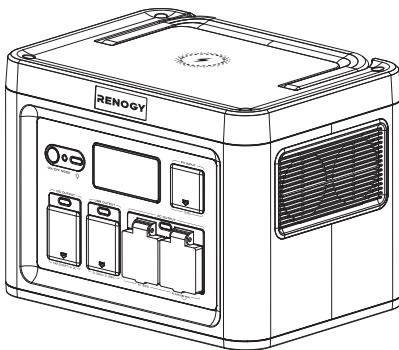

## Troubleshooting

### The device does not discharge

1. Check whether the connecting wire has been inserted in right place;
2. Check whether the total output power exceeds the rated output power;
3. Check whether the temperature of the equipment is too high.

### The device is not charging

1. Confirm that the AC socket on the wall and the AC charging cable are fully inserted into the AC
2. The device cannot be charged immediately after it is discharged. Please put it aside for an hour and try again, because it may enter the over-temperature protection.

## Specifications

### General

<b>Battery Cell Type</b>	Lithium Iron Phosphate
<b>Rated Capacity (0.5C, 25°C)</b>	25.6V, 42Ah/1075.2Wh
<b>Dimension</b>	14.17 x 10.31 x 10.47 in / 360 x 262 x 266 mm
<b>Net Weight</b>	34.4 lbs / 15.6 kg
<b>Output Waveform</b>	Pure Sine Wave

### Operation Parameters

<b>AC Input Voltage</b>	AC 200V-260V, 4.5A, 50Hz	
<b>AC Input Power</b>	AC 800W	
<b>PV Input</b>	DC 800W	
<b>Car Charging</b>	DC 12/24V, 8A	
<b>AC Output Voltage×2</b>	AC 240V, 50Hz	
<b>Rated Output Power</b>	Total 1600W	
<b>UPS Switching Time</b>	10ms	
<b>Cigarette Lighter Socket Output</b>	DC 12V, 10A	Total DC 12V, 10A
<b>DC Output×2</b>	DC 12V, 3A	
<b>USB-A Output×2</b>	DC 5V, 3A; DC 9V, 2A; DC 12V, 1.5A, 18W Max	
<b>USB-C Output×2</b>	DC 5V/9V/12V/15V, 3A; DC 20V, 5A, 100W Max	
<b>Wireless Charge</b>	9V, 10W	
<b>LED Light</b>	3W	
<b>Operating Temperature</b>	14 to 104°F (-10 to 40°C)	
<b>Charging Temperature</b>	32 to 104°F (0 to 40°C)	
<b>Storage Temperature</b>	-4 to 113°F (-20 to 45°C)	

## ■ Additional information

<b>IP Rating</b>	IP20
<b>Supply system (Input)</b>	TN system
<b>Supply to load system (Output)</b>	TN system
<b>Protective device characteristics</b>	Fuse used
<b>Icc</b>	13A
<b>Icw</b>	13A
<b>Icp</b>	0.5kA

The rated conditional short-circuit current(Icw) of UPS is less than 1kA.

This UPS complies with environmental service condition 3K2 of IEC 62477-1 (indoor use, pollution degree 2)

## PRODUCT MAINTENANCE

### ■ Maintenance

Check as needed.

- If the RPS1600AA Series power station cannot work regularly, charge and discharge it every 3 months under normal temperature to keep the service life.
- Regularly check all ports and wall chargers for any debris, dirt, damage, and corrosion.
- Do not disassemble the device privately.
- Do not cover the equipment with towels, clothes or other items.
- Regularly observe the side vents for dust and foreign matter, and clean them according to the cleaning procedures specified in the manual.

### ■ Disposal/Recycling

Do not put the device and its accessories in the trash can. Items must be properly handled in accordance with local laws and regulations.

### ■ Affirm

Copyrighted equipment. We all rights reserved. All trademarks cited here are the property of their respective owners. The information contained in this agreement is subject to change without notice. We are not responsible for technical or editorial errors or omissions contained in this agreement. First Edition: October 2025

## WARRANTY

We assure the original purchaser that our products are free of defects in workmanship and materials during the applicable warranty period determined in the “Warranty Period” section below, but the exclusions set below is excluded. This warranty statement sets total and exclusive obligations of us. We will not assume, nor authorize any person to assume for us any other liability related to the sale of our products.

### ■ Warranty time

The warranty is 24 months, and the warranty period is calculated by the original consumer purchaser from the date of purchase. In order to determine the start date of the warranty period, a sales receipt from the first consumer purchase or other reasonable documentary proof is required.

### ■ Repair processing

We will repair or replace any products that cannot be operated due to defects in workmanship or materials within the applicable warranty period. If a valid claim is filed within the applicable period, we

can choose:

1. Replacement product.
2. It can be exchanged with products of equal value. The replacement product bears the remaining warranty period of the original product or replaces it (90) days from the date of warranty, whichever is greater. The customer is responsible for the shipping cost of the return.

### Exclusions

The warranty of RPS1600AA Series does not apply to:

1. Any product that is modified, misused, abused, damaged by accident, or used for anything other than normal consumer use as authorized in current product literature.
2. Any product purchased through an online auction house. The warranty of RPS1600AA Series does not apply to the battery cell unless the battery cell is fully charged by you within seven days after you purchase the product and at least every 6 months thereafter.

### After-sales service

For after-sales maintenance service, please contact our customer service team.

## Renogy Support

**To discuss inaccuracies or omissions in this quick guide or user manual, visit or contact us at:**

 | [renogy.com/support/downloads](https://renogy.com/support/downloads)



 → [contentservice@renogy.com](mailto:contentservice@renogy.com)

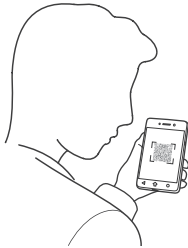

Questionnaire Investigation



**To explore more possibilities of solar systems, visit Renogy Learning Center at:**

 | [renogy.com/learning-center](https://renogy.com/learning-center)



**For technical questions about your product in the U.S., contact the Renogy technical support team through:**

 [support@renogy.com](mailto:support@renogy.com)

 1(909)2877111

**For technical support outside the U.S., visit the local website below:**

**Canada** |  | [ca.renogy.com](https://ca.renogy.com)

**China** |  | [www.renogy.cn](https://www.renogy.cn)

**Australia** |  | [au.renogy.com](https://au.renogy.com)

**Japan** |  | [jp.renogy.com](https://jp.renogy.com)

**Other Europe** |  | [eu.renogy.com](https://eu.renogy.com)

**Germany** |  | [de.renogy.com](https://de.renogy.com)

**United Kingdom** |  | [uk.renogy.com](https://uk.renogy.com)

**Join Our Facebook Community Today.** Scan the QR code to connect with like-minded people and Renogy engineers. You will get:

- Priority access to our latest launches & special events
- Insider Q&A sessions with our engineers
- Endless solar project ideas & sources



## Battery Recycling

The proper disposal and recycling of batteries are essential for environment protection and circular economy. We encourage correctly disposing of your batteries when they become depleted.

You can dispose your used batteries at any of [Call2Recycle](https://www.call2recycle.org) or [Earth911](https://www.earth911.com) locations that accepts Renogy rechargeable Lithium-ion and Lead-acid batteries (AGM&GEL).

 | [www.call2recycle.org/locator](https://www.call2recycle.org/locator)



 | [search.earth911.com](https://search.earth911.com)



## FCC Statement

This device complies with Part 15 of the FCC Rules. Operation is subject to the following two conditions:

- (1) This device may not cause harmful interference, and
- (2) This device must accept any interference received, including interference that may cause undesired operation.

This equipment has been tested and found to comply with the limits for a Class B digital device, pursuant to Part 15 of the FCC Rules. These limits are designed to provide reasonable protection against harmful interference in a residential installation. This equipment generates uses and can radiate radio frequency energy and, if not installed and used in accordance with the instructions, may cause harmful interference to radio communications. However, there is no guarantee that interference will not occur in a particular installation. If this equipment does cause harmful interference to radio or television reception, which can be determined by turning the equipment off and on, the user is encouraged to try to correct the interference by one or more of the following measures:

- (1) Orient or relocate the receiving antenna.
- (2) Increase the separation between the equipment and receiver.
- (3) Connect the equipment into an outlet on a circuit different from that to which the receiver is connected.
- (4) Consult the dealer or an experienced radio/TV technician for help.

## FCC Radiation Exposure Statement

This equipment complies with FCC radiation exposure limits set forth for an uncontrolled environment. This equipment should be installed and operated with minimum distance 20cm between the radiator & your body.



## Renogy Empowered

Renogy aims to empower people around the world through education and distribution of DIY-friendly renewable energy solutions.

We intend to be a driving force for sustainable living and energy independence.

In support of this effort, our range of solar products makes it possible for you to minimize your carbon footprint by reducing the need for grid power.



## Live Sustainably with Renogy

Did you know? In a given month, a 1 kW solar energy system will...



Save 170 pounds of coal from being burned



Save 300 pounds of CO<sub>2</sub> from being released into the atmosphere



Save 105 gallons of water from being consumed



## Renogy Power PLUS

Renogy Power Plus allows you to stay in the loop with upcoming solar energy innovations, share your experiences with your solar energy journey, and connect with like-minded people who are changing the world in the Renogy Power Plus community.



@Renogy Solar



@renogyofficial



@Renogy

Renogy reserves the right to change the contents of this manual without notice.

Manufacturer: RENOGY New Energy Co.,Ltd

Address: No.66, East Ningbo Road Room 624-625 Taicang German  
Overseas Students Pioneer Park JIangSu 215000 CN



eVatmaster Consulting GmbH  
Raiffeisen Street2 B11, 63110  
Rodgau, Hessen, Germany  
contact@evatmaster.com



EVATOST CONSULTING LTD  
Office 101 32 Threadneedle Street,  
London, United Kingdom, EC2R 8AY  
contact@evatost.com



Li-ion



RENOGY.COM

 **RENOGY**