

BACK

FRONT

INSIDE



QUICK CONNECT

WORK TOP

EASY QUICK CONNECT WORK TOP
TURN YOUR MODULAR STORAGE SYSTEM
INTO A MOBILE WORK SPACE

PLU: 722996
CODE: GS24-092
Manufactured and Packaged for
SRGS PTY. LTD.
ABN 23 113 230 050
6 Coulthards Avenue, Strathpine,
Queensland 4500, Australia.
MADE IN CHINA.



PRODUCT SPECIFICATIONS

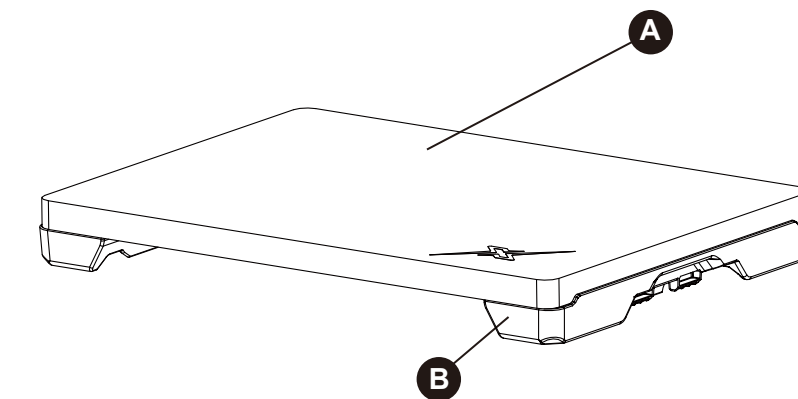

PART	DESCRIPTION
A	Top
B	Plastic Base

01.01

SAFETY INFORMATION

Please read and understand this entire manual before attempting to assemble or operate this product. Failure to follow may result in serious injury. Save all warnings and instructions for future reference.

WARNING

- Do not stand or step on this product. You may fall which may cause personal injury or product damage.
- To reduce the potential of the product toppling over, load the heaviest items towards the bottom.

CAUTION

- Ensure the wooden top is centered correctly on the tool box before next operation.
- Be careful when placed on top of tool box. The product may become unstable and tip, which may also cause personal injury or product damage.
- Always balance the load to avoid tipping. The product may become unstable and tip if stored on an unlevel surface, which may cause personal injury or product damage.
- Keep children and bystanders away while loading and/or unloading.
- Always use common sense and be cautious when using this product. Do not modify this product in any way.

OPERATING INSTRUCTIONS

1. Be sure that auto lock side latches are fully engaged when placed on top of tool box .

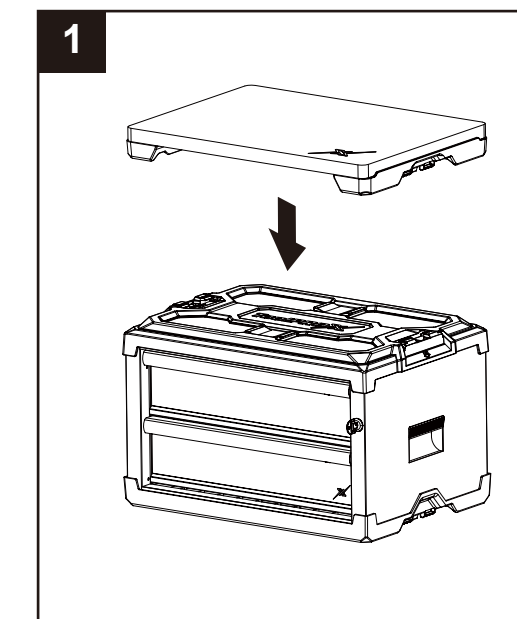
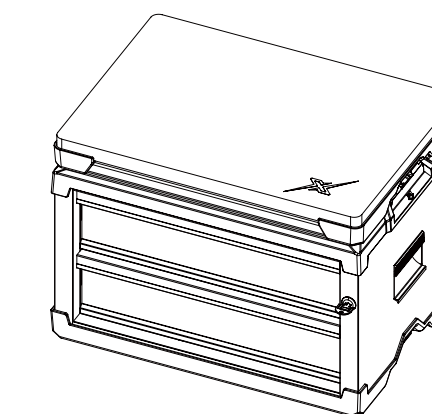

2. Unlock the mechanism by pulling the latches outwards.

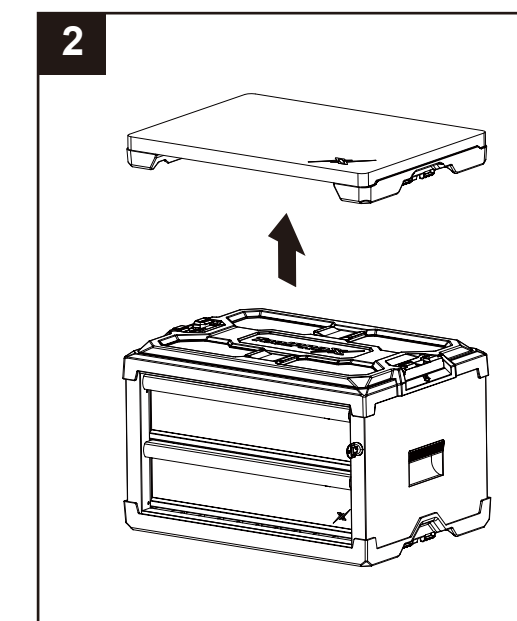
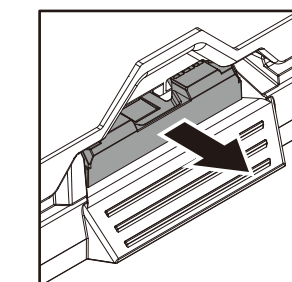

01.02



CARE AND MAINTENANCE

- Keep the product in good repair by adopting a regular maintenance program.
- Periodically clean the product surface with a mild detergent and water.
- Remove grease and oil with a standard nonflammable cleaning fluid.

3-YEAR WARRANTY

Our product is guaranteed to be free from quality and manufacturing defects for a period of 36 months.

If your product becomes defective during this period, SRGS PTY LTD will offer you either a replacement, credit or refund where a product is faulty; wrongly described; different from the sample shown to you or do not do what they are supposed to do.

This warranty will not cover substantially modified product; misuse or abuse of the product contrary to user instructions or packaging label; change of mind and normal wear and tear.

Our goods come with guarantees that cannot be excluded under the Australian Consumer Law. You are entitled to a replacement or refund for a major failure and for compensation for any other reasonably foreseeable loss or damage. You are also entitled to have the goods repaired or replaced if the goods fail to be of acceptable quality and failure does not amount to a major failure.

To claim the warranty, take the product to the front Service Desk of your nearest store of purchase. You will need to show receipt or other proof of purchase. Additional information may be required to process your claim. Should you not be able to provide proof of purchase with a receipt or bank statement, identification showing name, address and signature may be required to process your claim.

Any expenses relating to the return of your product to the store will normally have to be paid by you. For online store purchases, SRGS PTY LTD will pay for the return freight for any product assessed as having a major failure.

The benefits to the customer given by this warranty are in addition to other rights and remedies of the Australian Consumer Law in relation to the goods or services to which this warranty relates.

This warranty is provided by SRGS PTY LTD, 6 Coulthards Avenue, Strathpine QLD 4500, Australia. Phone: 1300 175 010.