

KÄRCHER

G 3000

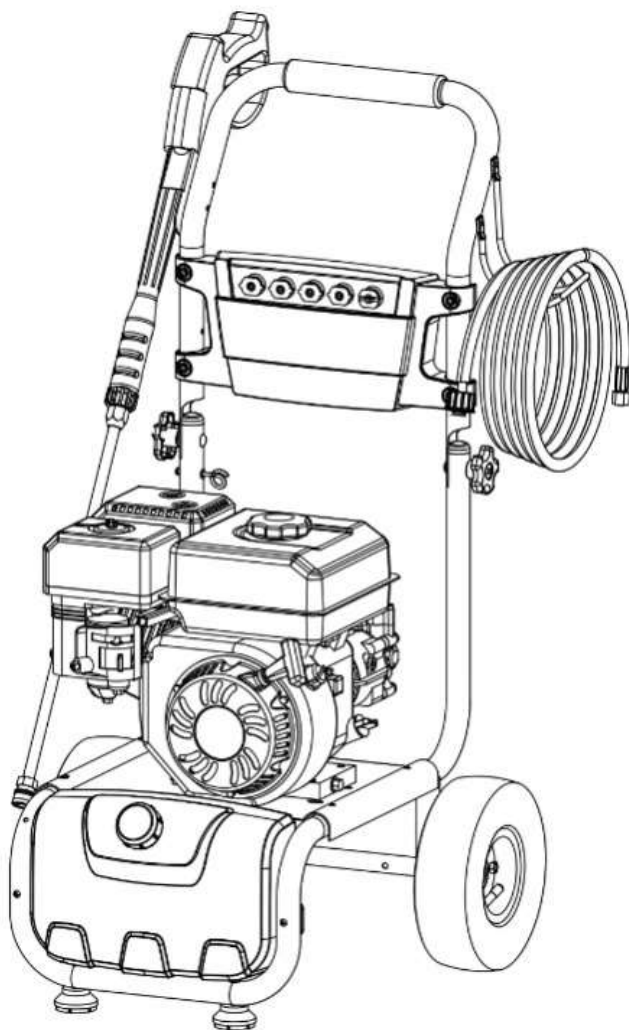

G 3000
9.506-954.0



Machine Parts List

1. Spray Gun
2. Nozzles
3. Muffler
4. Air Filter
5. Throttle Lever
6. Choke Lever
7. Fuel Valve
8. Detergent Tank Cap
9. Detergent Tank
10. Petrol Tank Cap
11. Petrol Tank
12. Hand Cord
13. Engine Switch
14. Oil Dipstick
15. Pressure Hose
16. Detergent Suction Connection
17. Pump Outlet
18. Pump Inlet
19. Thermal Release Valve
20. Spark Plugs
21. Tap Adapter

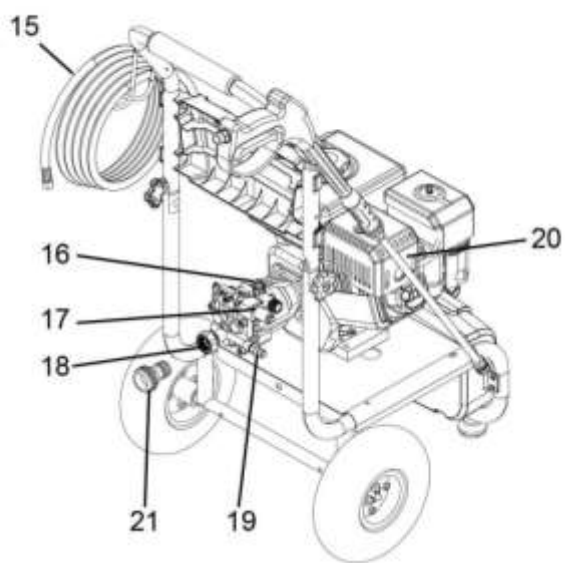
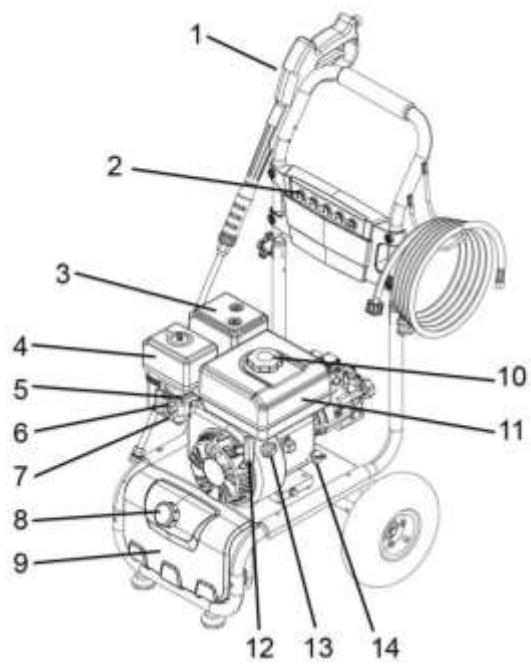

G3000



Please read and comply with these

original instructions prior to the initial operation of your machine and store them for later use or subsequent owners.

Engine Oil Type	SAE 10W-30
Model Number	9.506-954.0-
Serial Number	

Hazard Levels

Contents

Safety Instructions	5
Assembly Instructions	7
Preparation	9
Operating Instructions	11
Using the Accessories	13
Working with Detergents	14
Taking a Break ...five minutes or more	15
Shutting Down & Cleaning Up	15
Winterizing & Long Term Storage . . .	15
Maintenance Instructions	16
Cleaning Tips	16
Troubleshooting	19

DANGER

Indicates “an imminently hazardous situation which, if not avoided, will result in death or serious injury.”

WARNING

Indicates “a potentially hazardous situation which, if not avoided, could result in death or injury.”

CAUTION

Indicates “a potentially hazardous situation which, if not avoided, may result in minor or moderate injury or in property damage incidents.”

Specifications

G 3000

Operating Pressure	3000 PSI
Water Volume (minimum)	9.0 L/min
Engine	OHV
Fuel Type	Unleaded Petrol
Fuel Tank Size	3.0L

Safety Instructions

WARNING

When using this product, basic precautions should always be followed, including the following:

- Read the operating instructions of the engine manufacturer before start-up and follow the safety instructions carefully.
- Read all instructions before using product.
- To reduce the risk of injury, close supervision is necessary when the product is used near children.
- Know how to stop the product and bleed pressures quickly. Be thoroughly familiar with the controls.
- Stay alert - watch what you are doing.
- Do not operate when fatigued or under the influence of alcohol or drugs.
- Keep operating area clear of all persons.
- Do not overreach or stand on unstable support. Keep good footing and balance at all times.
- Wear safety goggles and ear protection.
- Follow the maintenance instructions specified in the manual.
- To avoid risks, all repairs and replacement of spare parts should only be carried out by authorized Karcher Service Agents.
- Tyre pressure should not exceed max. 25 psi.

WARNING

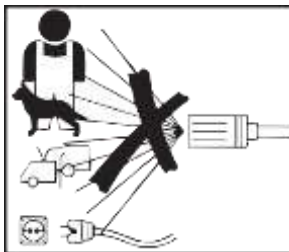

Risk of injection or injury – Do not direct discharge stream at persons.

- High pressure jets can be dangerous if misused. The jet must not be directed at persons, animals, electrical devices, or the unit itself.

DANGER

Do not spray electrical connections, electrical outlets or fixtures.

- Do not use acids, solvents, or any alkaline or flammable material in this product. These products can cause physical injuries to the operator and irreversible damage to the machine.

WARNING

Gun kicks back – Hold with both hands.

- The trigger gun safety lock prevents the trigger from accidentally being engaged. This safety feature must be engaged when replacing nozzles or not in use.

WARNING

- The muffler in this machine is extremely hot and dangerous. Extra care must be taken not to cause personal injury.

 **DANGER**



Risk of asphyxiation – Use this product only in a well ventilated area. Running this product indoors can result in death due to Carbon Monoxide, a poisonous gas you cannot see or smell. Only use outdoors and far away from windows, doors and openings or vents.

- Operate and fuel machine in a well ventilated area, free of devices featuring an open pilot or flame such as boilers, water heaters, etc.

 **CAUTION**

Risk of fire/explosion – Do not add fuel when the machine is operating or still hot.

 **WARNING**

Risk of fire/explosion -Operate only where open flame or torch is permitted. Do not spray flammable liquids.

- Do not operate if fuel has been spilled. Instead, move machine to different location and avoid creating sparks.
- This machine has hot surfaces which can cause burns. Operate in a safe environment and away from children.
- Do not touch hot surfaces or allow

accessories to contact hot surfaces.

- Do not leave machine running unattended.
- Avoid tipping machine on its side.

Water Supply (Cold Water Only)

 **CAUTION** 

When connecting to water supply mains, local regulations of your municipal water company must be observed. In some areas connecting directly to public drinking water supply may require a back flow prevention device. This is to ensure that there is no feedback of chemicals into the water supply. Use a water filter to avoid potential damage from dirt in the water supply.

- Garden hose must be at least 16mm diameter with a minimum 7.5m hose length.
- Flow rate of water supply must not fall below 9.0 L/min .
- Flow rate can be determined by running the water for one minute into an empty 10-litre container.
- The water supply temperature must not exceed 50°C.
- Never use the pressure washer to draw in water contaminated with solvents, e.g. paint thinners, gasoline, oil, etc.
- Always prevent debris from being drawn into the unit by using a clean water source. Use additional water filter.
- Do not operate pressure washer without the water turned on.

Assembly Instructions

Part List

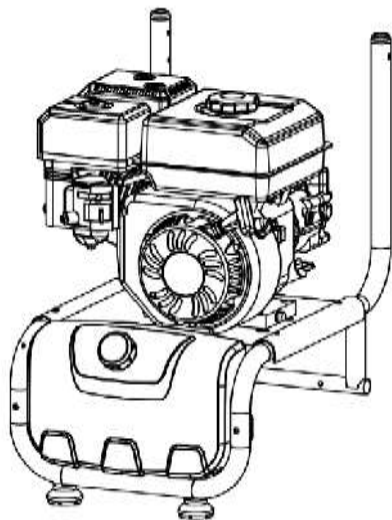

A - Main Frame



B - Handle



C - Gun Hook & Hose Hook



D - Knobs & Bolts



E - Pressure Hose

Assembling



F - Spray Gun & Wand



G- Wheels

Parts not shown:

- 1 - Manual
 - 1 - Nozzle Cleaner
 - 1 - Spark Plug Wrench
 - 1 - O-Ring Set
- (2 for pressure hose, 1 for spray gun)

1. Install the wheels to the main frame by pressing the spring loaded pin on wheel axle, then insert wheel axle into frame. Ensure that the spring pin is fixed in position. Repeat for the other wheel.

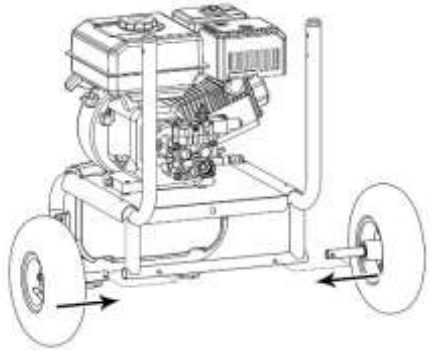

2. Attach the handle and main frame with knobs and bolts.



3. Attach the gun & hose hooks to the handle.

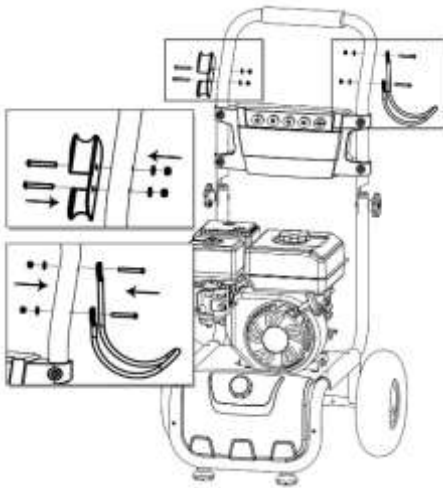

1. Remove the filler cap/dipstick and wipe it clean.

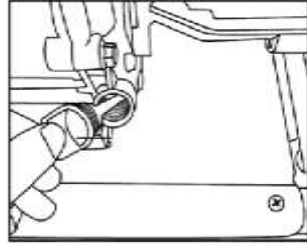

2. Insert and remove the dipstick without screwing it into the filler neck. Check the oil level shown on the dipstick.
3. If the oil level is low, fill to the edge of the oil filler hole with the recommended oil.

Preparation

Oil Level



Engine shipped without oil in crankcase. Before starting engine, fill with oil. Do not over-fill. Do not run the engine with a high or low oil level as this can cause engine damage. If you have further questions regarding the engine, please refer to the engine manual included with the unit.

Check the engine oil level with the engine stopped and in a level position.



Always use SAE 10W-30 oil.

Oil crankcase capacity: 0.6L.

4. Reposition the oil gauge dipstick and tighten it by turning clockwise.
5. Engine oil should be changed after the first 5 hours, then every 50 hours. Failure to change engine oil will void engine warranty.

Fuel Level

CAUTION

Make sure there is enough fuel in the fuel tank before operating. This is a 4-cycle engine and does not require a petrol/oil mixture. There is a separate reservoir for petrol and a separate reservoir for oil.

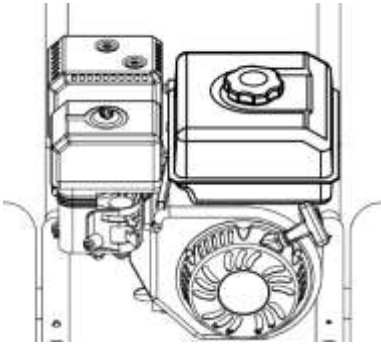

1. If it is necessary to add fuel, first make sure the engine is OFF, and then remove the fuel cap by turning it counter clockwise.
2. When refueling, make sure the fuel filter is in place and keep in mind all safety precautions.
3. Use clean unleaded petrol with a minimum of 87 octane. DO NOT use old petrol. DO NOT mix oil with petrol.

Fuel tank capacity: 3.0 Litre

Air Filter

CAUTION

The air filter should be checked after prolonged storage, the following steps should be done when checking the air filter. It is recommended to replace the air filter once every spring.

1. Remove the wing nut from the air cleaner cover, and remove the air cleaner cover.

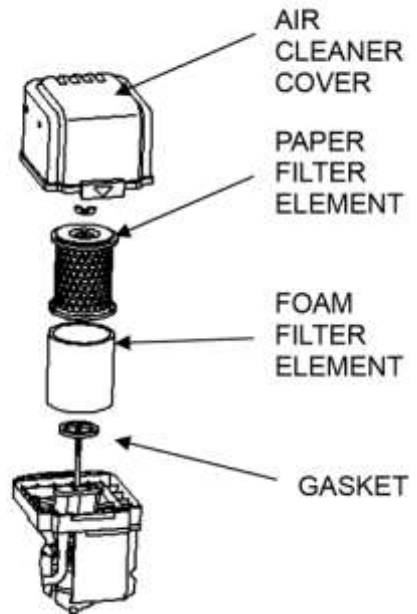

2. Remove the wing nut from the air filter, and remove the filter.
3. Remove the foam filter from the paper filter.

Operating Instructions

Starting Procedure:

1. Connect garden hose.

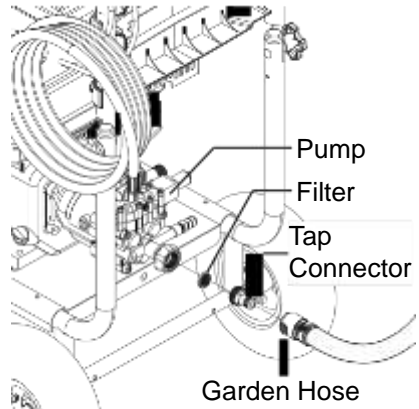

2. Connect spray gun and pressure hose.

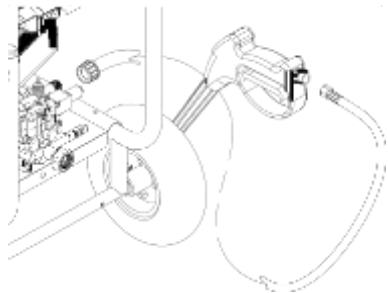

4. Inspect both air filter elements, and replace them if they are damaged. Always replace the paper air filter element at the scheduled interval.
5. Clean the air filter elements if they are to be reused.

Paper air filter element: Tap the filter element several times on a hard surface to remove dirt, or blow compressed air [not exceeding 30 psi (207 kPa)] through the filter element from the inside. Never try to brush off dirt; brushing will force dirt into the fibers.

Foam air filter element: Clean in warm soapy water, rinse, and allow drying thoroughly. Or clean in nonflammable solvent and allow drying. Dip the filter element in clean engine oil, and then squeeze out all excess oil. The engine will smoke when started if too much oil is left in the foam.

6. Wipe dirt from the inside of the air cleaner base and cover, using a moist rag. Be careful to prevent dirt from entering the air duct that leads to the carburetor.
7. Place the foam air filter element over the paper element, and reinstall the assembled air filter. Be sure the gasket is in place beneath the air filter. Tighten the air filter wing nut securely.
8. Install the air cleaner cover, and tighten the cover wing nut securely.

3. Open water source.

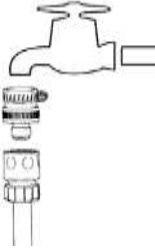

4. Start the Engine.

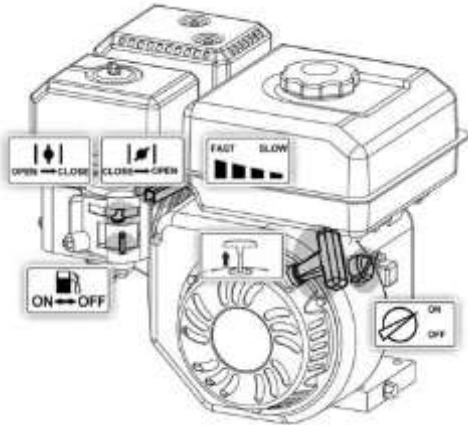

- ▶ STEP 3: Turn the fuel valve to "ON" position.
- ▶ STEP 4: Put the throttle lever to the "FAST" position.
- ▶ STEP 5: Pull trigger on spray gun to release pressure.
- ▶ STEP 6: Locate recoil cord and pull slowly until resistance is felt. At this point, pull rapidly to start engine.
- ▶ STEP 7: After the engine has started, turn the choke lever to "OPEN" position.

NOTE: If unable to start the engine, repeat the above operation one or two times.

NOTE: If the temperature is higher, such as during summer or if the engine is hot, choke valve should be switched to "OPEN" position before starting.

Cleaning Procedure:

Position the tip of the wand 15-20 cm (6"-8") away from the surface to clean at a 45° angle.

⚠ WARNING

Starter cord rapid retraction can result in Serious injury. Rapid retraction will pull hand and arm towards engine faster than you can let go. Always relieve spray gun pressure before pulling starter cord. Pull starter cord slowly until resistance is felt, then pull rapidly.

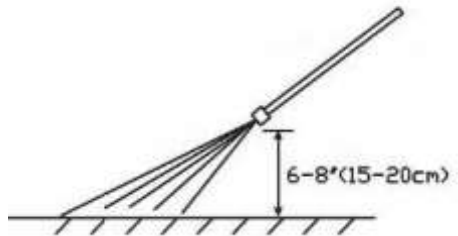

- ▶ STEP 1: Turn the engine switch to "ON" position.
- ▶ STEP 2: Move choke lever to "CLOSE" position.

Using the Accessories

The color-coded quick connect nozzles provide a wide array of spray widths from 0° to 40° and are easily accessible when placed in the convenient nozzle holder.

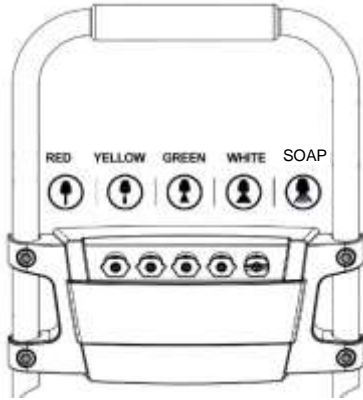

WARNING

High pressure in nozzle area. Risk of injury caused by improperly locked nozzle.

- Make sure you hear the "click" when inserting the nozzle tip into the quick connection.
- Pull the nozzle to make sure it is seated properly before operating your unit.

WARNING

To avoid serious injury never point spray nozzle at yourself, other persons or animals.

Adjusting Water Pressure

The pressure can be adjusted by changing the speed of the engine using the throttle lever.

Turning the throttle lever to the left can increase the speed to get more pressure.

Turning the throttle lever to the right can decrease the speed to get less pressure.

WARNING

When adjusting the engine throttle to the lowest setting, do not operate the pump. This can cause the engine to stall due to lack of power.

0° spray angle = Red nozzle

For particularly stubborn accumulation of grime. Not recommended for soft materials like sidings, decks, painted surfaces, cars.

15° spray angle = Yellow nozzle

For dirt accumulation over a surface.

25° spray angle = Green nozzle

For dirt accumulation over a large surface.

40° spray angle = White nozzle

For moderate dirt accumulation over a large surface.

Soap = Black nozzle

For operating with detergents or cleaning with low pressure.

Working with Detergents

Detergents can only be applied with the black detergent nozzle.

- Install the black detergent nozzle for detergent application at low pressure.
- Fill the detergent tank with Kärcher Brand Detergent.

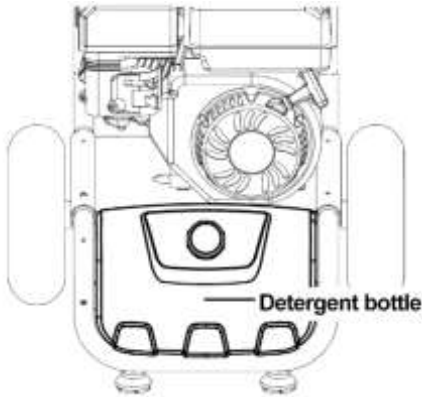

- With the engine running, pull trigger to operate unit.
- Liquid detergent is drawn into the unit and mixed with water.
- Apply detergent to work area.
- Do not allow detergent to dry on surface.
- Always flush the detergent bottle with fresh water when the cleaning job is done, to rinse/flush any remaining detergents from the injection system.

NOTE: For best results see Cleaning Tips for specific information on how to clean different surfaces.

CAUTION

This unit has been designed for use with cleaning detergents recommended by the manufacturer.

The use of other cleaning detergent may affect the operation of the machine and void the warranty.

Always Use Kärcher Detergent for Best Results.

Kärcher biodegradable detergents are specially formulated to protect the environment and your pressure washer. The special formula won't clog the filter and will protect the internal parts of the pressure washer for a longer life. For Kärcher Detergents, check your retailer or visit our website:

www.karcher.com.au or
www.karcher.co.nz

CAUTION

Never use:

- Bleach, chlorine products or other corrosive chemicals.
- Liquids containing solvents (i.e., paint thinners, gasoline, oils.)
- Tri-sodium phosphate products.
- Ammonia products.
- Acid-based products.

These chemicals will harm the unit and will damage the surface being cleaned.

Use of these items will void the warranty.

Taking a Break ...five minutes or more

- Move the engine stop switch to the OFF position.
- For engine details see engine manual.
- Release trigger and engage safety lock.

Shutting Down & Cleaning Up

- If detergents have been used, insert 1 litre of fresh water into Detergent Bottle. Siphon water at low pressure for one minute to clear the line of residual detergent.
- Move the engine stop switch to the OFF position. Close the fuel valve.
- Turn off the water source.
- Press trigger to release water pressure.
- Release trigger and engage gun safety lock.
- Disconnect the garden hose from the water inlet on the unit.
- Disconnect the high pressure hose from the high pressure outlet. Store the high pressure hose in the gun holder assembly.

Winterizing & Long Term Storage

Before winter storage and during the cleaning season, follow the following step to protect the pump from freezing and premature wear.

- Turn engine switch to the OFF position.
- Disconnect all hoses.
- Unscrew cap from Pump Guard bottle.
- Remove internal seal.
- Reattach cap to Pump Guard bottle and remove black protective cap.
- Screw bottle into water inlet on pressure washer pump and squeeze.
- With ignition OFF, pull starter rope until fluid starts to exit.
- Unscrew bottle. Store or dispose properly.
- If Kärcher Pump Guard is unavailable, perform the following:
- Disconnect all water connections.
- Turn on the machine for a few seconds, until the water which remained in the pump exits. Turn off engine immediately.



Failure to follow the above directions may result in damage to the pump assembly and accessories and void the warranty.

Do not allow high pressure hose to become kinked.

Store machine and accessories in a room which does not reach freezing temperatures. DO NOT store near furnace or other sources of heat as it may dry out the pump seals.

Maintenance Instructions

Pump

Pump Inspection

You should routinely make a visual inspection of the pressure washer's pump. If you notice oil leaking around the pump seals, you should take the pressure washer to a Kärcher Authorized Service Center for repair. (You can locate a service center in your area online at:

www.karcher.com.au . or
www.karcher.co.nz.)

Engine

Carry out maintenance tasks for the engine according to the specifications provided in the operating instructions provided by engine manufacturer.

Cleaning Tips

Deck Cleaning

With or Without Detergent

Pre-rinse deck and surrounding area with fresh water. If using Kärcher Universal Cleaner, apply to surface at low pressure. For best results, limit your work area to smaller sections of approximately 8 square meters. Allow Deck Wash to remain on surface 1-3 minutes. Do not allow detergent to dry on surface.

Rinse at high pressure in a long sweeping motion keeping the spray nozzle approximately 8-15cm (3-6 inches) from the cleaning surface. Always clean from top to bottom and from left to right. When moving on to a new section of the cleaning surface, be sure to overlap the previous section to eliminate stop marks and ensure a more even cleaning result.

Cars, Boats & Motorcycles

With or Without Detergent

Pre-rinse vehicle with fresh water. If using Kärcher Car Shampoo, apply to surface at low

pressure. For best results, clean one side of vehicle at a time and always apply detergent from bottom to top, do not allow detergent to dry on surface. If needed, use special wash brush attachment (not included) to remove stubborn dirt. Rinse at high pressure in a sweeping motion keeping the spray nozzle approximately 8-15cm (6-8 inches) from the cleaning surface (distance should increase when rinsing pin-striping or other sensitive surfaces). Always clean from top to bottom and from left to right. For best results, wipe surface dry with a chamois or soft dry cloth.

House Siding

With or Without Detergent

Pre-rinse cleaning surface with fresh water. If using Kärcher Universal

Cleaner, apply to surface at low pressure (for best results, limit your work area to sections of approximately 1.8M and always apply detergent from bottom to top). Allow detergent to remain on surface 1-3 minutes. Do not allow detergent to dry on surface, if surface appears to be drying, simply wet down surface with fresh water. If needed, use special wash brush attachment (not included) to remove stubborn dirt. Rinse at high pressure from top to bottom in an even sweeping motion keeping the spray nozzle approximately 15cm (6") from the cleaning surface.

Cement Patios, Brick & Stone

With or Without Detergent

Pre-rinse cleaning surface with fresh water. If using Kärcher Stone Cleaner or Degreaser, apply to surface at low pressure. For best results, limit your work area to smaller sections of approximately 8 square meters. Allow detergent or Degreaser to remain on surface 1-3 minutes. Do not allow detergent to dry on surface. Rinse at high pressure in a sweeping motion keeping the spray nozzle approximately 8-15cm (6-8 inches) from the cleaning surface. Always clean from top to bottom and from left to right. For removing extremely stubborn stains, use a DirtBlaster® Spray Nozzle (sold separately).

Barbecue Grills, Outdoor Power Equipment & Gardening Tools

With or Without Detergent

Pre-rinse cleaning surface with fresh water. If using Kärcher Universal Cleaner or Degreaser, apply detergent at low pressure. Allow detergent to remain on surface 1-3 minutes. Do not allow detergent to dry on surface. Rinse at high pressure keeping the spray nozzle approximately 8-15cm (3-6 inches) from the cleaning surface. For removing extremely stubborn dirt, it may be necessary to move the spray nozzle even closer to the surface for greater dirt cutting action.

Patio & Lawn Furniture

With or Without Detergent

Pre-rinse furniture and surrounding area with fresh water. If using Kärcher Universal Cleaner, apply to surface at low pressure. Allow detergent to remain on surface 1-3 minutes. Do not allow detergent to dry on surface. If needed use special Wash Brush Attachment (not included) to remove stubborn dirt. Rinse at high pressure in a sweeping motion keeping the spray nozzle approximately 8-15cm (3-6 inches) from the cleaning surface. For best results, clean from top to bottom and from left to right.

Recommendations

- Before cleaning any surface, an inconspicuous area should be cleaned to test spray pattern and distance for maximum cleaning results.
- If painted surfaces are peeling or chipping, use extreme caution as pressure washer may remove the loose paint from the surface.
- When using on surfaces which might come in contact with food, flush surfaces with plenty of drinking water.
- For additional cleaning tips, visit our website at www.karcher.com.au or www.karcher.co.nz

Optional Accessories

Optional accessories are available to further enhance your cleaning capabilities. These accessories are accurate as of the printing date of this manual. Please check our website: www.karcher.com.au for pricing and up to date information.

- Extension Hose
- DirtBlaster® Spray Nozzle
- Patio Cleaner
- Foam Nozzle
- Nozzle Kit
- Pipe Cleaning Kit
- 3.6m extension lance

Troubleshooting

CAUTION

Remove the spark plug cable to prevent accidental ignition of the engine before making any repair.

Symptom	Cause	Solution
Engine Will Not Start	No Petrol.	Fill Petrol Tank.
	Choke is not in the correct position.	Slide lever out to closed position.
	Ignition switch is not in the correct position.	Turn Ignition switch on.
	Water pressure built up in the machine.	Squeeze the trigger to release the pressure.
	For additional engine problems refer to the engine manual.	
Unit Does Not Reach High Pressure	Diameter of garden hose is too small.	Replace with a 16mm (5/8") or larger garden hose.
	Water supply is restricted.	Check garden hose for kinks, leaks and blockage.
	Not enough inlet water supply.	Turn water on full force. Check garden hose for kinks, leaks or blockage.
	Water inlet filter is clogged.	Remove filter and rinse out in warm water.
	Black detergent nozzle is attached.	Remove black detergent nozzle and attach high pressure nozzle.
Output Pressure Varies High And Low	Not enough inlet water supply.	Turn water on full force. Check garden hose for kinks, leaks or blockage.

Symptom	Cause	Solution
Output Pressure Varies Between High And Low	Pump is sucking air.	Check that hoses and fittings are air tight. Turn off machine and purge pump by squeezing trigger gun until a steady flow of water emerges through the nozzle.
	Water inlet filter is clogged.	Remove filter and rinse out in warm water.
	Spray nozzle is obstructed.	Blow out or remove debris with a fine needle.
	Calcified gun, hose or spray wand.	Run distilled vinegar through detergent tank.
No Detergent	Detergent suction tube not properly connected to the machine.	Check connection.
	Detergent is too thick.	Dilute detergent, for best results use Kärcher detergent.
	Filter on detergent suction tube is clogged.	Run warm water through filter to remove debris.
	Damaged or clogged detergent suction tube.	Remove obstruction or replace detergent suction tube.
	A high pressure nozzle is attached.	Replace with black detergent nozzle.
	Spray nozzle is obstructed.	Blow out or remove debris with fine needle.
Garden Hose Connection Leaks	Loose fittings.	Tighten fittings.
	Missing/worn rubber washer.	Insert new washer.

Symptom	Cause	Solution
Spray Wand Leaks	Spray wand not properly attached.	Turn the swivel nut of the gun clockwise until connection is tight.
	Broken o-ring or plastic insert.	Visit www.karcher.com.au or www.karcher.co.nz
Pump Is Noisy	Not enough petrol or engine oil.	Check that hoses and fittings are air tight. Turn off machine and purge pump by squeezing trigger gun until a steady flow of water emerges through the nozzle.
Water Leaks From Pump (Up To 10 Drop Per Minute Is Permissible)	Loose fittings.	Check fittings.
	Water seals are damaged or worn.	Visit www.karcher.com.au or www.karcher.co.nz
	Thermal protection device is activated.	Thermal protection device will auto reset. Do not run pump for more than 5 minutes without spraying.
Oil Drip	Oil seals are damaged or worn.	Visit www.karcher.com.au or www.karcher.co.nz

If the symptom you are experiencing is not listed above, or if the provided solutions do not solve your issue, please visit our extensive online troubleshooting database at:

www.karcher.com.au or
www.karcher.co.nz

Limited 24 month warranty Cold water petrol pressure washers

This Kärcher product is warranted by Kärcher to be free of defects in workmanship and materials under normal use.

Specific warranty applies to:

- Kärcher KPS and KXS series engines are warranted for two (2) years on parts and labor.
- Pumps and engines are warranted for two (2) years on parts and labor.
- Frames, handles and detergent tanks, as well as other structural components, carry a one (1) year parts and labor warranty.
- Standard accessories and attachments are warranted for a two (2) year period.
- Any trade, commercial, industrial or rental use of this equipment will reduce the warranty to one (1) year.

The warranty period is calculated from the date of purchase by the end user and covers cost for replacement parts / equipment and warranty labor performed. In order to verify a warranty situation, the machine must be evaluated by an Authorized Kärcher Service Center. A copy of the original purchase receipt or gift receipt from the original retailer must also accompany the warranty claim. To locate the nearest authorized Kärcher service center, please visit our website at www.karcher.com.au or www.karcher.co.nz.

Kärcher's obligation under this warranty shall strictly be limited, at Kärcher's option, either to replace or repair, through Kärcher direct or through an Authorized Kärcher Service Dealer without charge during the warranty period any part, which in the opinion of the manufacturer, shows defect in workmanship or material. Service will be scheduled according to the normal work flow and business hours at the service center, and availability of replacement parts. All decisions of Kärcher with regard to this limited warranty shall be final.

This warranty does not cover:

- Merchandise sold as reconditioned, used, demonstration or floor models.
- Merchandise purchased on eBay and other online auction web sites.

- Damage caused by misuse, neglect, accident, abuse, improper handling, freezing, normal wear and tear or non-compliance with operator's manual.
- Damage caused by water sediment, contaminated water supply or use of chemicals and detergents not approved by or recommended by Kärcher.
- Damage caused by acts of nature such as floods, fires, earthquakes, lightning strikes, etc.
- Devices or accessories not distributed or approved by Kärcher. Any use of such said devices or accessories will void implied warranty.
- Repairs made by the end user or any service center not authorized by Kärcher. Any such tampering with Kärcher equipment or accessories will void the implied warranty.
- Any cost for shipping by the customer or authorized service center of the alleged defective part or equipment.

This warranty is non-transferable and applies only to products purchased through a Kärcher authorized reseller in Australia and New Zealand .

This warranty gives you specific legal rights. You may have other rights, which vary by country and state/province.

Please register online at www.karcher.com.au. or www.karcher.co.nz. Online registration is quick, free and provides you with a confirmation email for your records.

If you do not have internet access, please return the warranty registration card included in the accessory bag. It is not necessary to use an envelope. Please remember to use a first-class postage stamp. The Postal service will not deliver without a stamp.