

BLACK RIDGE

POWERED BY AIR

50LPM QUIET INFLATOR

*Quiet portable inflator for
general light duty tasks
around the home*

**MODEL NO.
BR50iS**

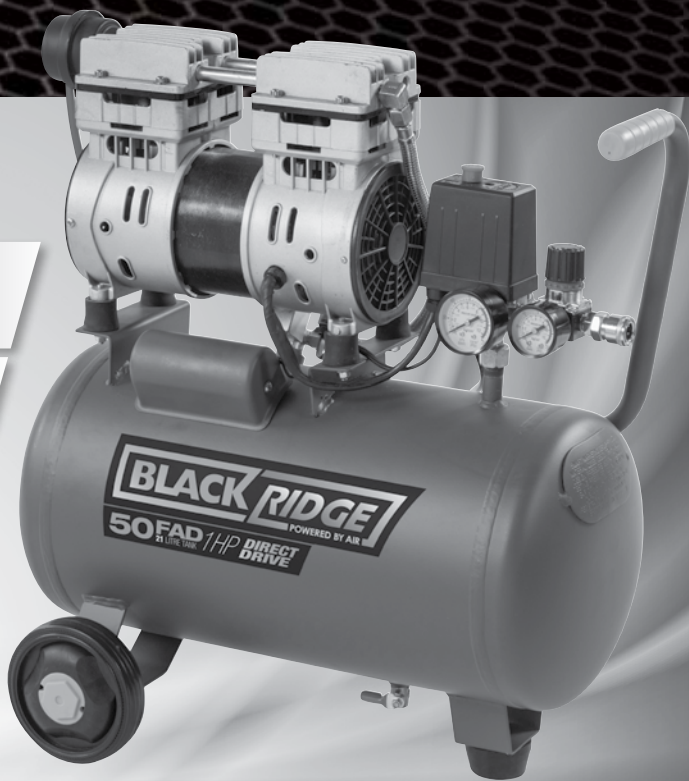

*For service, spare parts or product information,
please contact Smart Marketing Group Pty. Ltd.*

AUST. 1300 660 457 N.Z. 0800 474 876



Recyclable
Cardboard

SUGGESTED APPLICATIONS

You may use most light duty air tools with this inflator. Some examples of light duty tools are:

- Ball Inflator
- Toy Inflator
- Tyre Inflator
- Airbrush
- Stapler
- Combo Nailer

This inflator is NOT recommended for use with a spray gun or medium duty air tools. Always check the air requirement of the tool wishing to be used to ensure that it is within this inflator's air output. Attaching air tools that draw more than 50 litres per minute, free air delivery, to this inflator, may cause them not to operate to the tools' full potential. The listed air tools and accessories above are not included with this inflator.

Specifications

Inflator	BR50iS
Voltage	240V AC ~ 50Hz
Motor	1 HP
Wattage	750W
	Oil Free
No Load Speed	1400 RPM
FAD (Free Air Delivery)	50L per minute
Tank Size	21L
Duty Cycle	50%
Max Tank Pressure	115PSI (8BAR)
Outlet Pressure	1PSI - 115PSI - Adjustable
Lubrication	Oil Free
Minimum Generator Size	Pure Sine Wave 1500W
Noise Rating	67dB@3m
Motor/Pump	Kicks In 85PSI
Pressure Cycle	Stops 115PSI
Number Of Outlets	1

CONTENTS

Section	Page
Contents	2
Suggested Applications	2
Introduction	3
Guarantee	3 – 4
General Safety Instructions	5 – 7
Electrical Information	8
Components and Controls	9
Operating Instructions	10 – 14
Maintenance	14
Trouble Shooting	15
Technical Information	15
Parts Diagram	16
Contact Information	16

INTRODUCTION

Dear Customer,

Thank you for purchasing this inflator which has passed through our extensive quality assurance processes. Every care has been taken to ensure that it reaches you in perfect condition. However, in the unlikely event that you should experience a problem, or if you require any assistance please do not hesitate to contact us;

If you have a problem, call customer service do not return this inflator to the place of purchase.



Note: For convenience we suggest taking a photocopy of your purchase receipt as the original may fade.

CUSTOMER SERVICE

Australia: 1300 660 457

New Zealand: 0800 474 876

Operating times: Monday – Friday

8.00am - 5.00 pm

Australian Eastern Standard Time (AEST)

EXPRESS WARRANTY STATEMENT INFLATOR

You are not required to do anything to register your inflator purchase. Please attach the purchase receipt to this manual and ensure both are kept safe. We hope you enjoy your new inflator, and if you have any problems call customer service on the above phone numbers. Do not return to place of purchase.

Smart Marketing Group Pty Ltd (SMG) warrants that this inflator will be free from manufacturing faults or defects for 12 months from the date of purchase, providing original purchase receipt is kept and shown when needed and is subject to the terms and conditions below.

If a warranty fault appears within the warranty period, SMG reserves the right to replace or repair the product. In the event that SMG chooses to replace the product, this original warranty will expire at the original date. If the product includes various accessories or components, only the defective accessory or component will be replaced or repaired.

SMG reserves the right to replace defective parts of the product with parts and components of similar quality, grade and composition where an identical part or component is not available.

Products presented for repair may be replaced by refurbished products of the same type rather than being repaired. Refurbished parts may be used to repair the products.

What is covered.

- Manufacturing fault or defect.

How to claim under this warranty.

- Call customer service, phone number to the left.
- Ensure you have the following: Original purchase receipt, Model of inflator, Serial number of inflator.
- Discuss the issue.
- Customer service will advise which authorised service agent to take the inflator to provided the issue is a warranty one.
- Take inflator to authorised service agent for repair.

What is not covered.

- Commercial use of inflator.
- Use of inflator in a commercial premises.
- Damage caused by incorrect fuel or incorrectly mixed 2 stroke fuel.
- Damage or deterioration due to transport.
- Damage caused by negligence, misuse, abuse or accident or incorrect voltage and wattage.
- Any corrosion or rusting.
- Damage caused by incorrect set up and start up.
- Replacement parts due to general wear and tear.
- Inflators with serial number defacement, modification or removal.
- Inflators which have been serviced by other than an authorised SMG service agent.
- Inflators with no original purchase receipt.
- Inflators which have been on sold, not original purchaser.
- Damage due to non-servicing of inflator as is required by this manual.
- Blockages / damage caused by dust, dirt, spiders webs or insects.
- Damage caused by the incorrect fitting of accessories.
- Damage caused by overloading, overworking the inflator.
- Damage to attached equipment or third party accessories.
- Damage caused by attached equipment or third party accessories.

CONTACT DETAILS

Smart Marketing Group Pty Ltd

33-35 Lionel Road, Mt. Waverley

Victoria 3149, Australia.

Tel (+613) 9543 7266

Fax (+613) 9543 9839

service.group@sitro.com.au

COMPLETE WARRANTY STATEMENT – INFLATOR

As soon as you have purchased the inflator, we recommend that you check to make sure it is intact and that you read the operating instructions carefully before using it. The purchase receipt for this product is to be retained and must be presented if making a claim under the terms of the Smart Marketing Group (SMG) warranty. Bank account statements are not acceptable for proof of purchase.

This warranty does not cover inflators intended for hire or use in commercial applications or in commercial premises. The warranty will under no circumstances extend to reimbursement or payment of damages, whether direct, indirect or consequential. The warranty is void if there is evidence the inflators has been modified or tampered with in any way or used with unauthorised accessories without our consent.

SMG declines any responsibility or liability whatsoever arising from misuse or abuse, negligent handling of the inflators or if the product has not been installed or failure to comply with the relevant safety, operating, setting and maintenance instructions (see further in this manual).

The warranty does not extend to installation or disconnection costs.

Any item sent freight forward/collect for repair will be refused. Warranty repairs are free of charge, provided the appliance is delivered to our service department or authorised service agent. The inflator will need to be returned, adequately protected in a box. SMG will not be responsible for any in-transit loss or damage. Assistance under the warranty will only be made available if the request is made to our customer service team on the contact numbers listed below and proof of purchase is provided.

This is a repair only warranty you will need to take the inflator to the authorised service agent after contacting our customer service centre.

If the product includes various accessories or components, only the defective accessory or component will be replaced or repaired.

SMG reserves the right to replace defective parts of the product with parts and components of similar quality, grade and composition where an identical part or component is not available.

Products presented for repair may be replaced by refurbished products of the same type rather than being repaired. Refurbished parts may be used to repair the products.

Damage caused by third party accessories is not covered under this warranty.

Damage caused to attached equipment or third party accessories will not be covered under this warranty.

Rust and corrosion are not covered under this warranty.

If a warranty fault is found the freight cost will be credited to the owner. If no fault is found the product will be returned and any costs associated with the service will be charged to the owner.

Blockages caused by spider webs, insects, dirt, accumulated dust, incorrect fuel or incorrectly mixed 2-stroke fuel are not covered by warranty. SMG reserves the right to replace or repair the appliance within the warranty period. Parts found to be defective due to a manufacturing default will be replaced free of charge.

In the event of SMG choosing to replace the appliance, the warranty will expire at the original date of purchase. If no warranty fault is found the owner will be advised and the product will be returned and any costs associated with the service will be charged to the owner.

Our goods come with guarantees that cannot be excluded under the Australian Consumer Law. You are entitled to a replacement or refund for a major failure and for compensation for any other reasonably foreseeable loss or damage. You are also entitled to have the goods repaired or replaced if the goods fail to be of acceptable quality and the failure does not amount to a major failure. The benefits of this warranty are in addition to any rights and remedies imposed by Australian State and Federal legislation that cannot be excluded.

In New Zealand, this SMG warranty is in addition to the conditions and guarantees which are mandatory as implied by the New Zealand Consumer Guarantee Act 1993. For service, spare parts or product information please contact customer service:

CONTACT DETAILS

Smart Marketing Group Pty Ltd
33-35 Lionel Road, Mt. Waverley
Victoria 3149, Australia.
Tel (+613) 9543 7266
Fax (+613) 9543 9839
service.group@sitro.com.au

LUBRICATION OF INFLATOR

This inflator is OIL FREE. Therefore there is NO oil used for lubrication.

ASSEMBLY

This inflator **MUST** be fully assembled by you prior to use. Failure to do so will result in the warranty being VOID. Failure to fully assemble this inflator may also result in personal injury.

MANOEUVRING

When moving this inflator always use the handle to lift slightly and pull/push using the attached wheels. If you must lift this inflator always use a 2 person lift due to its weight and size. Failure to use 2 person lift may result in personal injury.

SAFETY

Before attempting to operate this inflator the following basic safety precautions should be taken to reduce the risk of fire, electric shock and personal injury. It is important to read the instruction manual and to understand applications, limitations and potential hazards associated with the inflator. This inflator is not intended for use by persons (including children) with reduced physical, sensory or mental capabilities, or lack of experience and knowledge, unless they have been given supervision or instruction concerning the use of the appliance by a person responsible for their safety.

BEWARE OF CHILDREN AND PETS

Children and pets should be kept out of the work area. Children should not be allowed to touch or operate the inflator, tools or extension cords. This inflator is not designed for use by young children or infirm persons without supervision. The inflator and tools should be kept out of reach of children, preferably stored or locked in a secure cabinet or room when not in use.

WORK AREA

Work areas and benches should be kept tidy. Cluttered benches and work areas can cause accidents. Floors should be kept clean and free from rubbish. Special care should be taken when the floor is slippery due to sawdust or wax. Always leave sufficient distance, at least 5 metres between the inflator and the work area, especially when using tools designed for sanding or spraying liquids.

WORK ENVIRONMENT

Do not expose your inflator to rain or use in damp or wet conditions. Keep the work area well lit.

GUARD AGAINST ELECTRIC SHOCK

Avoid body contact with earthed or grounded surfaces (e.g. pipes and refrigerators).

DO NOT OVERLOAD INFLATORS

The inflator will do a better, safer job and give you much better service if it's used at the duty cycle for which it was designed. The duty cycle will only take effect after the initial (1st) tank fill for the day. This inflators duty cycle is 50%. Duty cycle is the proportion of time during which the inflator is operating compared with not operating. For example a 50% duty cycle could mean after 30 seconds of operation, motor pumping, the inflator must be left for 30 seconds resting, motor not pumping. When the motor is pumping the attached air tool can not be used. Only use the attached air tool while the inflator is not pumping. Stop using the attached tool as soon as the inflator starts pumping.

USE THE RIGHT TOOL

Select the right tool for the job. Do not use a tool for a job for which it was not designed. Do not force a small inflator to do the job of a heavy-duty inflator. Do not use the inflator for purposes not intended.

DO NOT ABUSE THE POWER CORD

Never yank or pull on the power cord to disconnect it from the mains supply socket. Never carry or pull your inflator by its power cord. Keep the power cord away from heat, oil, solvents and sharp edges. Regularly check the plug and cord and if damaged have it replaced by an authorised service facility.

EXTENSION CORDS AND REELS

This inflator **MUST** be plugged directly into a 240V AC wall socket.

This inflator is **NOT** designed to be run off an extension cord/lead. If you need extra distance do **NOT** use an extension cord, **USE A LONGER AIR HOSE**.

The use of extension cords may cause power voltage loss and will result in damage to the motor. This will **NOT** be covered under warranty.

SECURE THE WORK PIECE

Whenever possible secure the work piece using clamps or a vice. It is safer than using your hands or feet and leaves both hands free to control the tool.

HOT COMPONENTS

Beware many of the components will get hot during use. Never touch any of the metal pipes, pump or motor as these may burn.

MAINTAIN YOUR INFLATOR WITH CARE

Follow the instructions for use and changing accessories. Check the inflator power cord periodically and if damaged have it replaced by an authorised service facility. Keep handles clean, dry and free from oil and grease. Ensure that ventilation slots are kept clean and free from dust at all times. Blocked ventilation slots or air filter can cause overheating and damage to the motor and this will not be covered under warranty.

DISCONNECT INFLATOR

Ensure that the inflator is disconnected from the mains supply when not in use, before servicing, making adjustments or when changing any accessories.

REMOVE ADJUSTING KEYS AND WRENCHES

Form the habit of always checking to see that any adjusting keys or wrenches have been removed from the inflator or attached air tools before operating.

AVOID UNINTENTIONAL STARTING

Ensure that the switch is in the 'OFF' position before plugging the inflator into the mains supply.

PROTECT FURNISHINGS

If using the inflator inside your house, protect furnishings and floors with a suitable dust sheet.

FIRE PRECAUTIONS

When using the inflator inside your house or workshop general fire precautions should be observed. This means never leaving your inflator turned on while not in attendance, never cover the inflator while being used or while still hot from use, never use in areas where a spark may cause a fire, always use in clean areas. As a precaution it is recommended that an expert is consulted on obtaining and using a suitable fire extinguisher.

CLEANING YOUR INFLATOR

NEVER UN-ASSEMBLE your inflator to clean.

Always disconnect your inflator from the mains power supply before you commence cleaning. Always ensure that your inflator has cooled, about one (1) hour, before cleaning and storing. When cleaning your inflator use only a damp soft cloth. **NEVER** use liquid or solvents of any type.

CHECK DAMAGED PARTS

Before using the inflator it should be carefully checked to determine that it will operate properly and perform its intended function.

Check for the correct alignment of moving parts ensuring that they do not bind. Check for broken or missing parts and have them replaced or repaired at an authorised service facility. Check any other condition that may affect the operation of the inflator. A guard or any other part of the inflator that is damaged should be properly repaired or replaced by an authorised service facility unless otherwise indicated in this instruction manual.

Any switch that does not operate correctly must be replaced by an authorised service facility.

DO NOT use the inflator if the 'ON / OFF' button does not turn the inflator 'ON' and 'OFF'.

DO NOT use the power point switch to operate the inflator as this will cause damage and injury may occur. Any damage will not be covered under warranty.

For assistance, product information, spare parts or service please contact Smart Marketing Group Pty. Ltd.

AUST. 1300 660 457

N.Z. 0800 474 876

PERSONAL SAFETY

Clothing

Do not wear loose clothing, jewellery or anything that could get caught in moving machinery.

Hair

Long hair should be tied back or contained in a protective covering.

Eye Protection

The use of safety goggles is highly recommended (normal glasses are not sufficient for eye protection) when using inflator. Prescription glasses do not have safety lenses.

Footwear

Where there is the risk of heavy objects or if there is a risk of slipping on wet or slippery floors, suitable non-slip safety footwear should be worn. Protect your feet from dropping accidents.

Ear Protection

The use of ear protection is highly recommended when using inflators. The continual noise may damage your ears.

Respiratory Protection

When operating any machinery that creates dust or when spray painting, an approved dust / filter mask must be worn. When machining concrete, man made fibres, especially MDF (Medium Density Fibre board), the resin used in these materials can be hazardous to your health. Use an approved face mask with replaceable filter.

Do Not Over Reach

Do not over reach. Keep a proper footing and maintain your balance at all times. Avoid using abnormal stances and awkward body positions.

Stay Alert

Watch what you are doing, use common sense, and never operate a inflator when you are tired, drinking alcohol, taking drugs or if taking medication that causes drowsiness.



WARNING

Only use inflator when fully assembled.

Do not attempt to modify the inflator in any way; this will VOID your warranty.

The use of any attachment or accessory other than those recommended in this instruction manual could result in damage to the inflator and could cause injuries to the operator.

This electric inflator complies with Australian / New Zealand and International standards and safety requirements. Repairs should only be carried out by qualified persons using original spare parts. Failure to do so may result in considerable danger to the operator.

IMPORTANT



ELECTRICAL DATA

This inflator is fitted with a sealed electrical connection plug that is compatible with the mains power supply for Australia / New Zealand and meets the requirements of Australian Standards. This inflator must be connected to a supply voltage that is equal to that stated on the rating label. If the mains power connection plug or power cord becomes damaged it must be replaced with a complete assembly that is identical to the original, and this must be replaced by an authorised service centre. Always follow the Australian / New Zealand requirements for connection to the mains supply. If in doubt always consult a qualified electrician.

SPECIFIC SAFETY INSTRUCTIONS

Warning! Do not use the inflator in areas where there is a risk of explosion or fire from combustible materials. The sparks generated from certain tools attached to inflator can ignite combustible materials as well as flammable liquids, paint, varnish, petrol, flammable gases and dust of an explosive nature. As a precaution it is recommended that you consult an expert on a suitable fire extinguisher and its use.

- **Do not attempt to modify the inflator, guards or the supplied accessories in any way.**
- **Domestic inflators are designed for intermittent operation. Ideally a 50% duty cycle. (Meaning. 30 seconds ON motor pumping and 30 seconds OFF, motor not pumping). When the motor is pumping the attached air tool can not be used. Only use the attached air tool while the inflator is not pumping.**
- **Stop using the attached tool as soon as the inflator starts pumping.**
- **Fully assemble inflator before use.**
- **Always ensure your inflator is level and stable.**
- **Never use an extension cord with this inflator always use a longer air hose.**
- **Never connect to a generator which does not produce sufficient power, at least 1500W and has pure sine wave power output.**
- Domestic inflators are not designed for industrial / commercial applications.
- Domestic inflators are not designed for continuous running. Always follow duty cycle - 50%.
- Avoid touching the pump area as it can become very hot and may burn.
- Ensure that the inflator is disconnected from the mains supply when not in use, before servicing, making changes and when changing attachments such as air hoses / tools.
- Always use the correct type of tool for the operation to be carried out.
- Never use the inflator if any part of the unit is damaged. Always have the inflator serviced by an authorised service agent.
- Always wear safety eye, ear and respiratory protection when operating the inflator.
- Allow the tank to completely fill before using the inflator.
- If the inflator makes an unfamiliar sound or vibrates excessively, switch the inflator 'OFF' immediately and disconnect from the mains power supply. Investigate the possible cause or consult your authorised service facility.
- Always move the inflator using the handle and wheels.
- Always use the inflator on stable ground.
- This inflator is designed to compress normal air. Never use to compress any other type (s) of gases.
- Never direct the jet of air or other liquids / gases towards your body, other persons or animals.
- Never direct the jet of air or other liquids / gases towards this inflator.
- This inflator is not suitable for pharmaceutical, food or sanitary purposes.
- This inflator is not to be used to fill scuba or oxygen air bottles or tanks.
- Always follow the instructions relating to the tools attached to this inflator.

PIC. 1

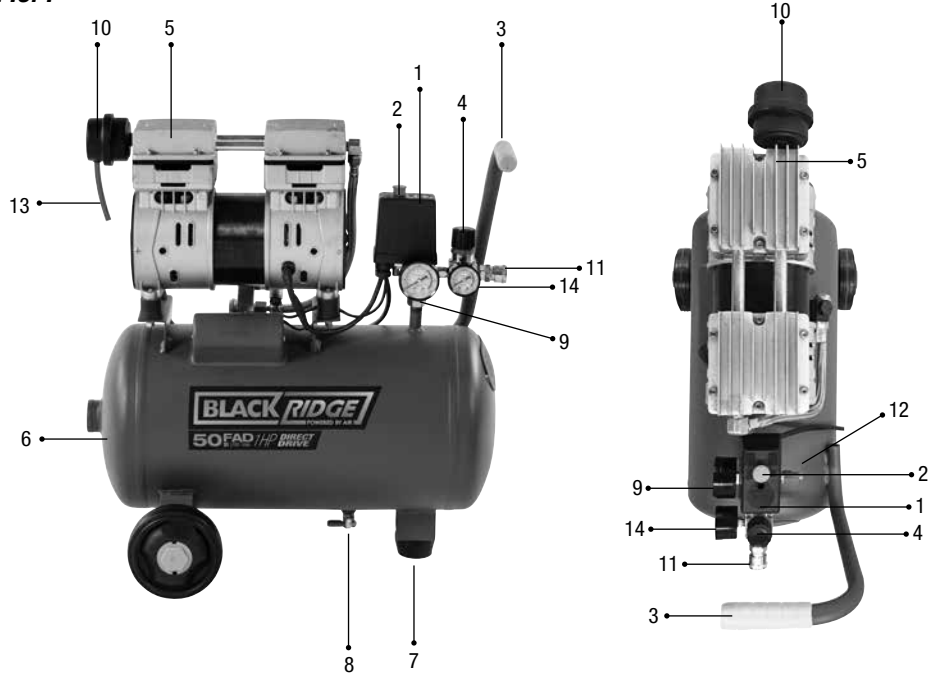

COMPONENTS AND CONTROLS

Pic. 1

1. Pressure switch
2. On / Off button - red colour
3. Handle
4. Outlet pressure regulator
5. Pump
6. Tank
7. Rubber feet
8. Tank drain tap
9. Tank pressure gauge
10. Air filter
11. Air outlet - nitto style socket
12. Safety valve
13. Air Filter "Quieting Tube"
14. Outlet pressure gauge

OPERATING INSTRUCTIONS

Unpacking

Carefully unpack your inflator. Dispose of all packing material in an environmentally responsible manner. When unpacking this inflator always use a 2 person lift due to its weight and size. Failure to use 2 person lift may result in personal injury. Dispose of all packing material in an environmentally responsible manner.

Assembly

Your inflator requires minor assembly before initial operation. Check that you have all required components required for assembly and initial use.

Rubber Stopper

To attach the rubber stopper to the bracket located on the bottom of the tank;

1. Undo the nut and remove the washer.
2. Push through the bracket and replace the washer.
3. Tighten the nut, Pic. 2

Air Filter

The supplied air filter must be used.

Failure to do so may result in irreparable damage and will void the warranty, Pic. 3

To install;

1. Carefully screw supplied air filter into the threaded hole on the top of the pump head. This only needs to be done up by hand. Do not use tools to tighten air filter.

NOTE: Do not OVER TIGHTEN as this may damage the air filter or cylinder head which will NOT be covered under warranty.

Once air filter is installed, fit the quieting tube. The quieting tube pushed into the small air filter inlet hole.

Wheels

1. Insert a bolt through the wheel.
2. Push through the tank wheel bracket.
3. Tighten the nut, Pic. 4.



WARNING

Do not attempt to operate this inflator until it is fully assembled.

Damage caused due to incomplete assembly will not be covered under warranty.

Ensure the inflator is disconnected from the power supply before carrying out any assembly, maintenance or adjustments on the machine.

PIC. 2



PIC. 3



PIC. 4



STARTING AND STOPPING YOUR INFLATOR

Pic. 5

NOTE: Always ensure that you plug your inflator into a standard 240V AC power point. Never use an extension cord as this can lead to a voltage drop which may cause power loss and over heating. Use a longer air hose if you need to get closer to your work area.

Always start and stop the inflator using the ON/OFF button on the Pressure Switch (Pic. 5). Damage caused by not using this button will not be covered by warranty.

To turn your inflator ON;

Lift up the red ON / OFF button on top of the pressure switch

To turn your inflator OFF;

Push down the red ON / OFF button on top of the pressure switch

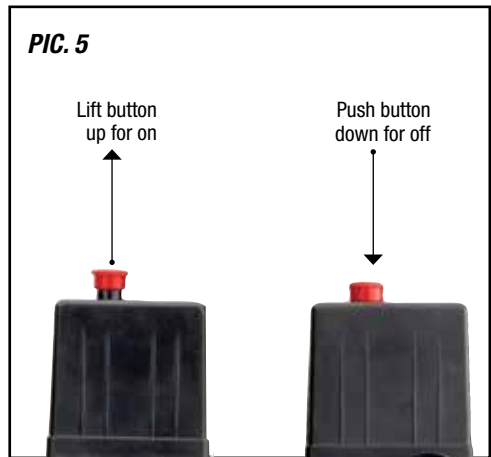

RUNNING IN YOUR NEW INFLATOR

Your inflator does not require running in. Before use ensure you have read and understood these instructions.

Before use ensure this inflator is fully assembled as per page 10.

POSITIONING YOUR NEW INFLATOR

Choose a location away from your work area and near to a mains power point.

- NOTE:
1. Never use an extension lead. Always use a longer air hose
 2. Always position inflator on level ground
 3. Always position inflator away from work area so that the inflator does not get covered in dust or paint - use a longer air hose to ensure inflator is in clean air

USING THE INFLATOR

Before starting run through this simple list;

1. Fully assembled.
2. Drain tap – open and drain tank
3. Drain tap – close fully
4. Check power lead for any damage. If damaged have replaced by an authorised service centre.
5. Plug inflator into a standard 240V 10Amp AC power point and turn ON.
6. Lift the red button to turn ON, see page 11, Pic.4.
7. Allow the inflator to fill the air tank.
8. Turn the inflator OFF.
9. Turn the power point OFF and disconnect the power lead from the power point.
10. Connect your air hose and air tools.
11. Reconnect to the power lead to the power point and turn ON.
12. Turn your inflator ON.
13. Once turned on and you begin using the connected air tools the inflator will start and stop without warning. This is controlled by the pressure switch. These pressure settings are factory set and should not be changed.

Pumping starts at (minimum) 85PSI and stops at (maximum) 115PSI. Once the initial pump up stage has finished you can use the inflator. Remember to adjust the outlet air pressure to the tools recommended working pressure.

TOOL CONFIGURATION

The configuration of tools and accessories can be varied to suit your particular requirements. A basic recommended set up is shown in Pic. 6 (accessories not included).

When you have finished using your inflator follow these simple steps:

1. Turn your inflator OFF, using the ON/OFF button.
2. Turn the power point OFF and disconnect the power lead.
3. Disconnect your air tools and air hose.
4. Clean your air hose and air tools.
5. Store your air hose and air tools in a secure well ventilated cabinet.
6. Slowly open the tank drain tap, see page 14. This allows excess air and moisture, water, to vent.
7. Leave the tank drain tap open. This allows any moisture to drain while the inflator is stored.

NOTE: Use of a water trap may be of benefit to ensure no water or moisture reaches your air tools.



ADJUSTING THE PRESSURE

To adjust the outlet air pressure, use the outlet pressure regulator knob and check the pressure on the outlet pressure gauge, Pic. 7.

If the pressure needs to be lower, turn anti clockwise.

If the pressure needs to be higher, turn clockwise.

Use the gauge to ensure you set the correct working pressure.

Note: Different air tools require different operating pressures. Always check with the tool manufacturer if unsure.

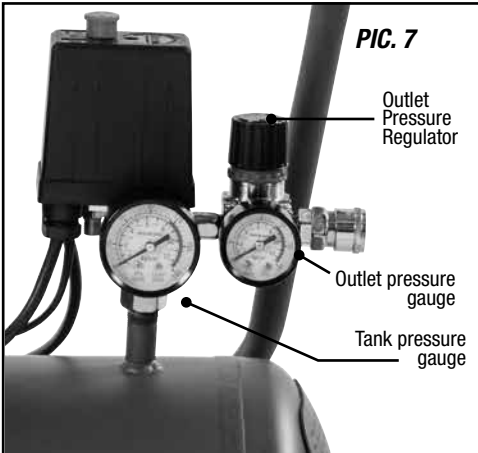

SAFETY VALVE

Pic. 8

NOTE: When checking the safety valve ALWAYS wear safety glasses.

To check the operation of the safety valve the air tank will need to be full. Gently pull the ring outwards. This should release air under pressure. Release the ring and this should stop the air out flow once the pressure has dropped.

If the safety valve does NOT work in this manner, STOP the inflator immediately and have the inflator checked / serviced by an authorised service centre.

IMPORTANT



This compressor has a maximum pressure of 8 bar. Always regulate the air pressure to match your air tool. Different air tools require different operating pressures. Always check with the tool manufacturer if unsure.

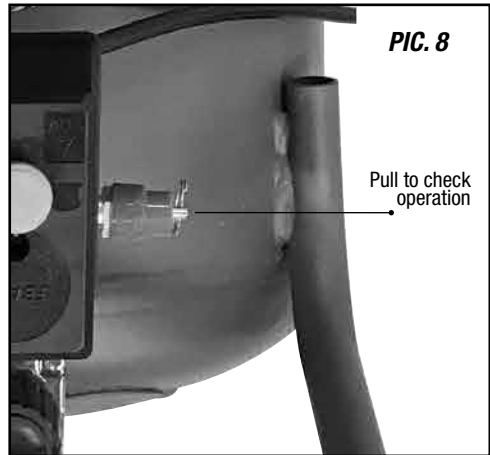

AIR OUTLET

Pic. 9

This air compressor is fitted with a 'Nitto style' (female) socket.

1. Slide the outer collar down.
2. Push in the 'Nitto style' male plug (not included).
3. Release the collar.
4. Fully and completely push the 'Nitto style' male plug (not included) into the 'Nitto style' female socket until it clicks.

Note: This compressor has a maximum pressure of 8 bar. Always regulate the air pressure to match your air tool. Different air tools require different operating pressures. Always check with the tool manufacturer if unsure.

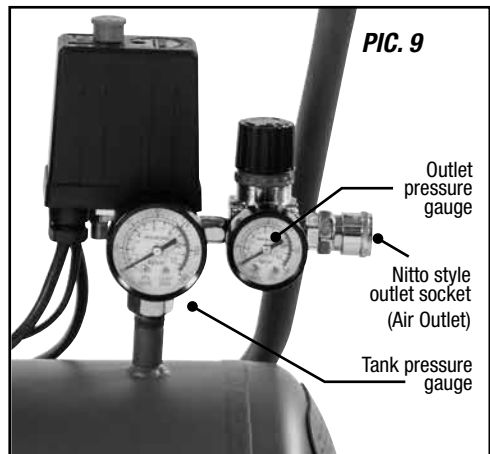

DRAIN TAP

Pic. 10

After use open the drain tap to drain excess air and any moisture. The excess air will also help purge the moisture. Leave the drain tap open when inflator is not in use, so any moisture can continue to drain

To open the drain tap pull the lever down to vertical.

To seal the drain tap push the lever up to horizontal.

NOTE: Remember to seal the drain tap before starting the inflator.

MAINTENANCE

Daily: Before Use

1. Seal the tank drain tap, see above, Pic. 10.
2. Check safety valve operation, see page 13, Pic. 8.

After Use

1. Open the tank drain tap, see above.
2. Wipe down the inflator.
3. Store safely and securely.

CLEANING

ENSURE the inflator is NOT running whilst cleaning. To keep the inflator clean, always wipe down after use. Wear eye protection when cleaning. Only clean the inflator with a damp soft cloth. NEVER use liquid or solvents of any type. Ensure ventilation slots are kept clean and free from dust/dirt build up.

STORAGE

When storing ensure the air tank has been emptied as per 'Drain Tap' above. Always store away from children, preferable in a locked room.

IMPORTANT



NOTE

This inflator has a maximum pressure of 8 bar. Always regulate the air pressure to match your air tool. Different air tools require different operating pressures. Always check with the tool manufacturer if unsure.

PIC. 10

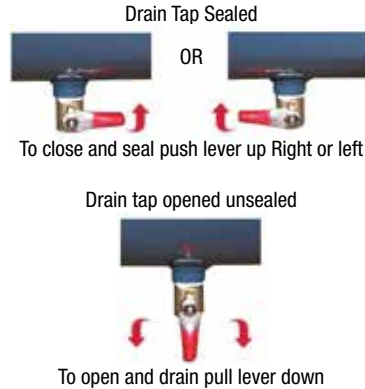

REPAIRS

Repairs to your inflator should only be carried out by an authorised service agent.

Call BLACKRIDGE for your closest centre, Aust.
Aust. 1300 660 457 N.Z. 0800 474 876.

? TROUBLE SHOOTING

Inflator will not start

Check that you have plugged the power lead into a standard 240V 10Amp power point and turned the switch ON.

Check that you have turned the inflator ON/OFF switch ON.

The air tank may be full. Use your air tool and the inflator should start when the pressure decreases to 85PSI.

Inflator does not build up pressure

Check that the tank drain tap is sealed

Check that the air fitting is not leaking. If leaking replace.

Inflator smells like burnt oil

Using beyond the 50% duty cycle, allow to cool for 30 minutes before reusing this inflator.

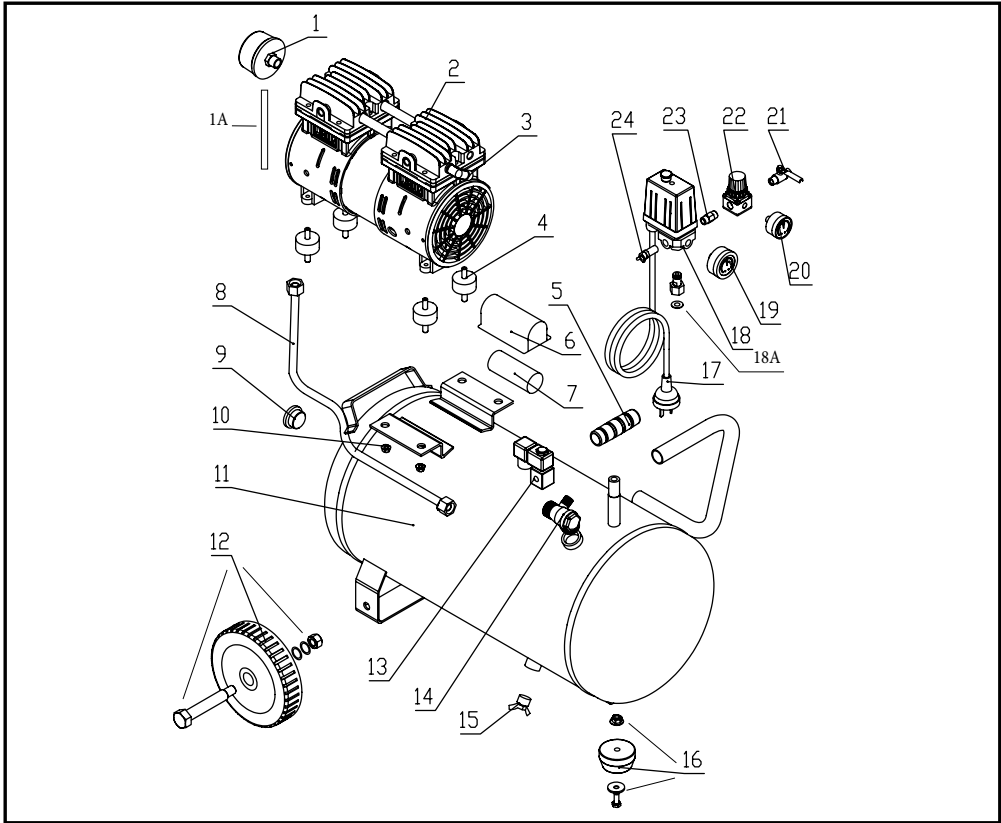

Part	Description	SMG Part No.
1	Air filter	95 BRS50AF
1A	Air filter tube	95 BRS50AFT
3	Exhaust Elbow	95 BRS50ET
24	Safety valve	95 BRC95SPV
18	Pressure Switch	95 BRC95PS
23	Connector	95 BRC95PTC
22	Regulator Single Tap	95 BRC950PRS
21	Outlet nitto style socket (female)	95 BRI40NSF
19	Pressure Gauge Large	95 BRC95TPG
20	Pressure Gauge Small	95 BRC950PG

Part	Description	SMG Part No.
14	One Way Valve	95 BRC950WV
5	Rubber Handle Grip	95 BRS50TH
15	Drain Tap	95 BRC95DT
16	Cushion Foot, Nut, Washer & Screw	95 BRS50AS
12	Bolt, wheel and Screw Nut	95 BRS50WH
8	Exhaust Tube and Nut	95 BRS50ET
4	Motor Mounts	95 BRS50MM
13	Electric Depressure	95 BRS50ED

User replaceable parts listed above. All other parts must be serviced/replaced by an authorised service agent.

Specifications

Inflator	BR50IS
Voltage	240V AC ~ 50Hz
Motor	1 HP
Wattage	750W
	Oil Free
No Load Speed	1400 RPM
FAD (Free Air Delivery)	50L per minute
Tank Size	21L
Duty Cycle	50%
Max Tank Pressure	115PSI (8BAR)
Outlet Pressure	1PSI - 115PSI - Adjustable
Lubrication	Oil Free
Minimum Generator Size	Pure Sine Wave 1500W
Noise Rating	67dB@3m
Motor/Pump	Kicks In 85PSI
Pressure Cycle	Stops 115PSI
Number Of Outlets	1

For any queries or assistance call Customer Service
AUST. 1300 660 457 NZ 0800 474 876

Hours of operation:

Monday to Friday 8.00am - 5.00pm AEST

**Do not return to place of purchase. Keep your purchase receipt, this will
be required to make any claims under the 12 month warranty.**

Blackridge® is a registered trademark of Super Cheap Auto Pty Ltd

BLACK RIDGE
POWERED BY AIR