



35L Wet & Dry Workshop Vacuum Cleaner Instruction Manual



Manufactured and packaged for SRGS PTY LTD ABN 23 113 230 050
751 Gympie Road, Lawnton, Queensland 4501, Australia



35L Wet & Dry Workshop Vacuum Cleaner

Instruction Manual



WARRANTY

This product is guaranteed against defects for a period of 12 months from date of purchase. This warranty is provided by Super Cheap Auto Pty Ltd ACN 085 395 124 (Supercheap Auto) of 751 Gympie Rd Lawnton QLD 4501 Ph (07) 3482 7500. Supercheap Auto will offer a repair, replacement product or store credit if the product is assessed as being defective during the warranty period.

To claim under this warranty, take this product to the Front Service Desk of your nearest Supercheap Auto store. For store locations, visit www.supercheapauto.com.au (AUS) or www.supercheapauto.co.nz (NZ). You will need your receipt or proof of purchase. Additional information may be requested of you to process your claim. Should you not be able to provide proof of purchase with a receipt or a bank statement, identification showing your name, address and signature may be required to process your claim.

This product may need to be sent to the manufacturer to assess the defect before determining any claim. Faults or defects caused by product modification, misuse and abuse, normal wear and tear or failure to follow user instructions are not covered under this warranty.

Our goods come with guarantees that cannot be excluded under the Australian Consumer Law. You are entitled to a replacement or refund for a major failure and for compensation for any other reasonably foreseeable loss or damage. You are also entitled to have the goods repaired or replaced if the goods fail to be of acceptable quality and the failure does not amount to a major failure.

Any expenses incurred relating to the return of this product to store will normally have to be paid by you. For more information contact your nearest Supercheap Auto store.

The benefits to the consumer given by this warranty are in addition to other rights and remedies of the Australian Consumer Law in relation to the goods and services to which this warranty relates.

IMPORTANT SAFEGUARDS

When using an electrical appliance, basic precautions should always be followed, including the following:

READ ALL INSTRUCTION BEFORE USING THIS VACUUM CLEANER

WARNING

To reduce the risk of fire, electric shock, or injury:

- Do not use outdoors.
- Do not leave vacuum cleaner when plugged in. Turn off the switch and unplug the electrical cord when not in using and before servicing.
- Do not allow to be used as a toy. Close attention is necessary when used by or near children.
- Use only as this manual described. Use only manufacturer's recommended attachments.
- Do not use with damaged power cord or plug.
- Do not pull or carry by cord, use a cord as a handle, close door on cord, or pull cord around sharp edges and corners. Do not run this item over cord. Keep the cord away from heated surface.
- Do not use extension cords or outlets with inadequate current carrying capacity. Turn off all controls before unplug.
- Do not unplug by pulling on cord. To unplug, grasp the plug, not the cord.
- Do not handle plug or vacuum cleaner with wet hands or operate without shoes.
- Do not put any object into openings. Do not use with any opening blocked; Keep free of dust, lint, hair, and anything that may reduce airflow.
- This vacuum cleaner creates suction. Keep hair, loose clothing, fingers, and all parts of body away from openings and moving parts.
- Do not pick up anything that is burning or smoking, such as cigarettes, matches, or hot ashes.
- Do not use without dust bag or filter in place.
- Use extra care when cleaning on stairs.
- Do not use to pick up flammable or combustible liquids such as gasoline, or use in areas where they may be present.
- Store your cleaner indoors in a cool, dry area.
- Ensure you turn the unit off at the very minimum every 15 minutes (for 1 minute) to let the motor cool down - failure to do so may cause motor failure.
- Do not use this unit for more than 4 hours (including rest breaks) on any given day.
- If the supply cord is damaged, it must be replaced by the manufacturer.
- This cleaner must be operated in accordance with these instructions. This cleaner is not designed for industrial applications and should not be used for collection of cement dust, fiberglass dust, excessive or frequent sand or body fillers as these will be harmful to your motor and void the manufacturers warranty.
- This appliance is not intended for use by persons (including children) with reduced physical, sensory or mental capabilities, or lack of experience and knowledge, unless they have been given supervision or instruction concerning use of the appliance by a person responsible for their safety.
- Children should be supervised to ensure that they do not play with the appliance.

PARTS NAME

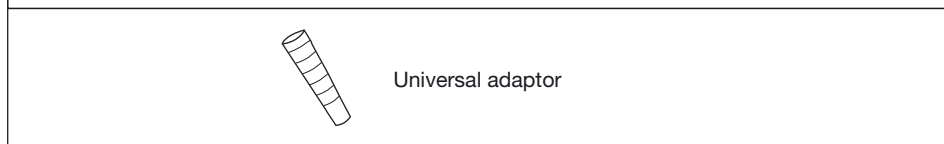
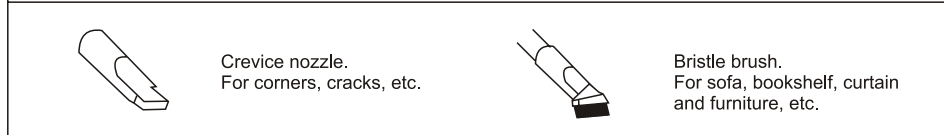
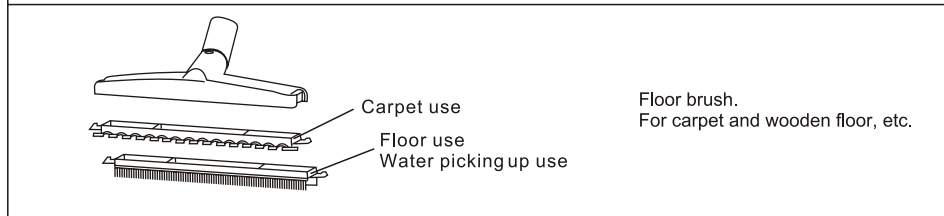
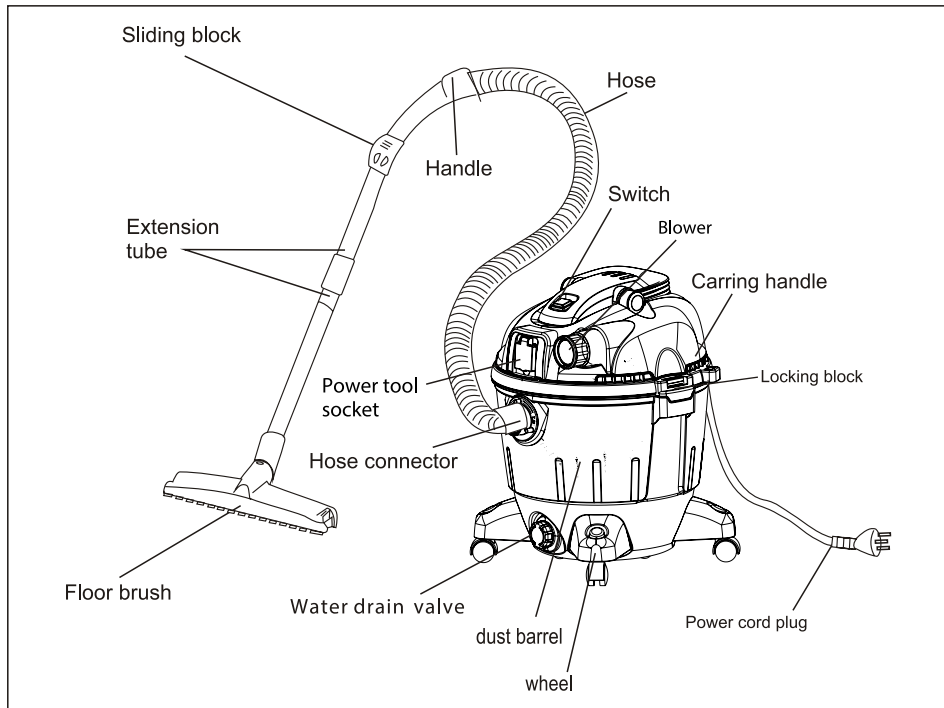

OPERATION METHOD

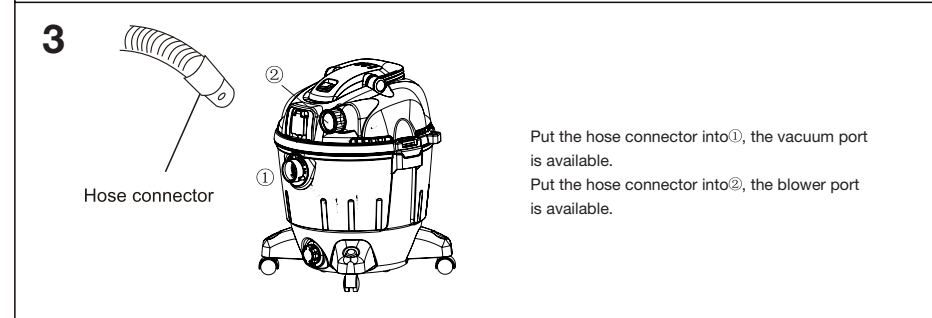
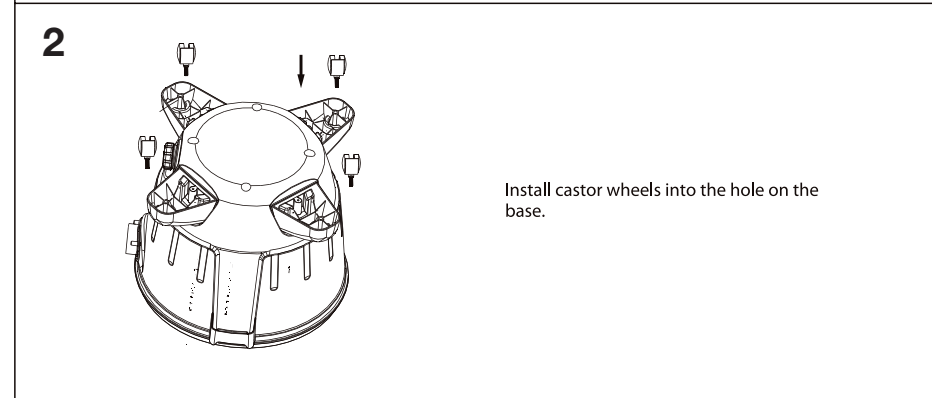
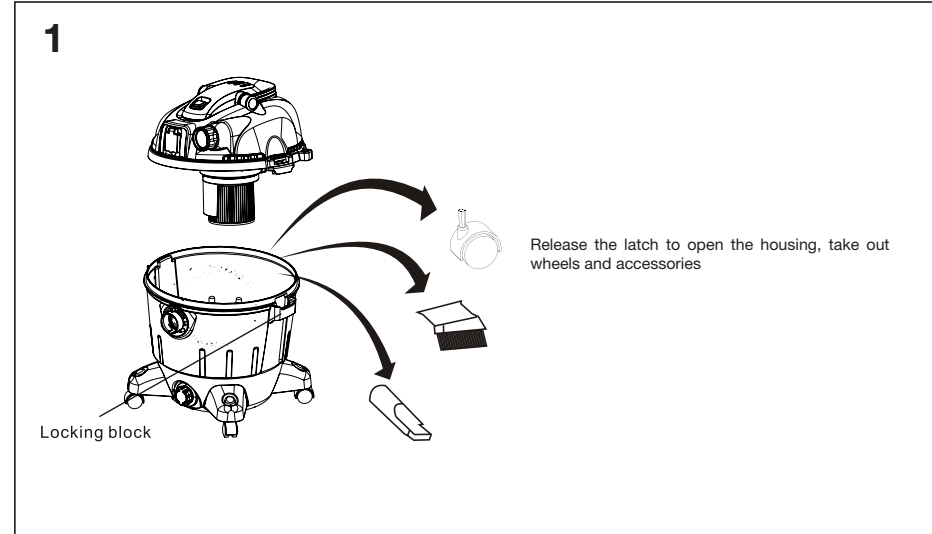

OPERATION METHOD

4

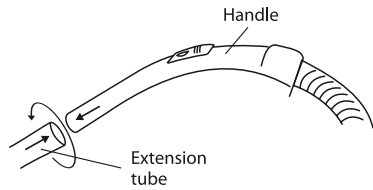

Insert the handle into the tube with a twisting force.

5

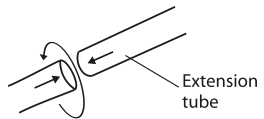

Push tubes together with a twisting force

6

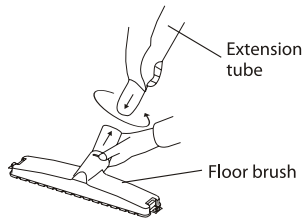

Connect the floor tool with a twisting force

7



HEPA filter



Foam Filter

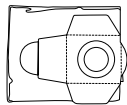

Dust Bag

Using HEPA filter and dust bag for dry vacuuming.
Using foam filter for wet vacuuming, always dry the foam filter after using.

Never use the machine without filters.
Never use the dust bag for wet vacuuming.

OPERATION METHOD

8

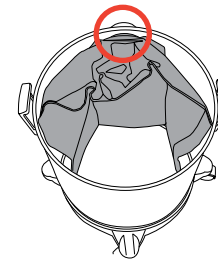

Fitting the dust bag:
Slip the dust bag over the vacuum inlet to fit the dust bag.

9

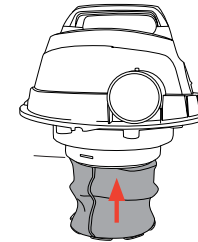

Fitting the foam filter:
For wet-vacuuming, slip the foam filter over the filter basket.

10

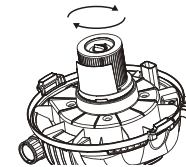

Fitting the HEPA filter:
Put the HEPA filter over the filter basket and twist the locking knob with a clockwise force to fit the HEPA filter.

OPERATION METHOD

11

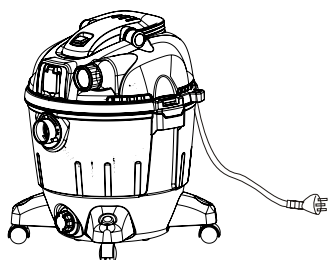

Hold the plug and insert into socket

12

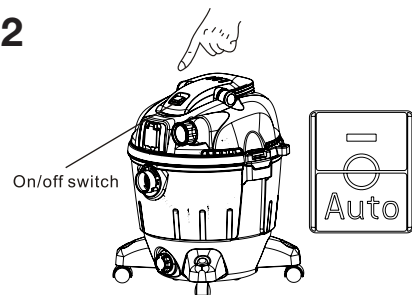

On/off switch

Press the switch button to turn on/off the cleaner.

To be safe there is a water-proof switch cover. Please replace the water-proof cover if damaged.

13

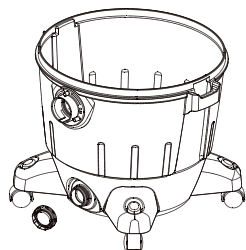

Take off the cover let water drain

14

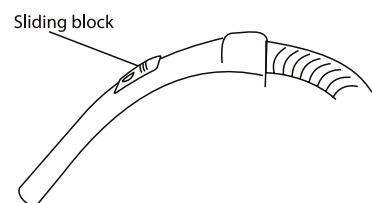

Sliding block

You can adjust the airflow by push the sliding block up and down.

TO CLEAN DUST BARREL

If the dust barrel is full, please empty it as soon as possible

1

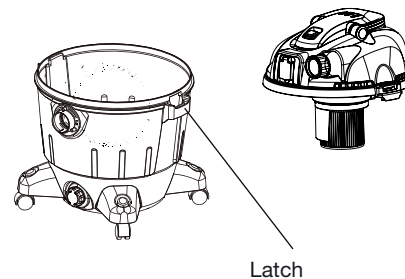

Release the latch to open the housing

Latch

2

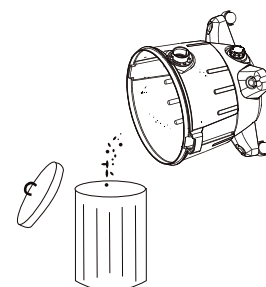

Empty the dust barrel

3

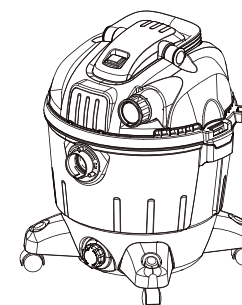

Reassemble the housing and fasten the latch

MAINTENANCE

Warning: when the filters are obviously filled with dust or suction decreases considerably, please clean it promptly, which can improve the working efficiency and extend the life of the cleaner.
Never use the appliance without the filter.

1 Tear off the mesh

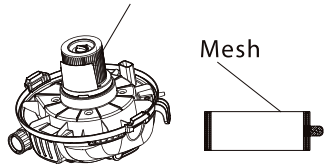

Tear off the mesh outside the HEPA filter

2

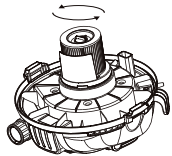

Twist the locking knob with a anti-clockwise force, take off the filters

3

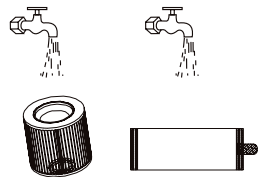

Gently wash the filter using mild soap and water
Rinse thoroughly

4

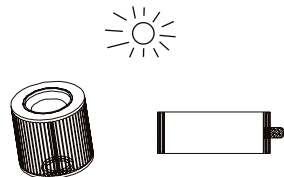

Dry by airing

5

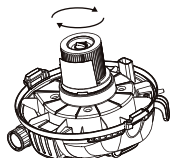

Reinstall the filter

SPECIFICATION

Rated voltage: 220V-240V ~ 50Hz

Rated input power: 1200W (2200w with socket outlet)

Airflow: 1.8 m³/min

Vacuum pressure: 16 Kpa

Noise: 76 dB(A)

Capacity: 35L

Cable length: 4.5M