

# 2 Way Component Speaker System

Instructions

GB

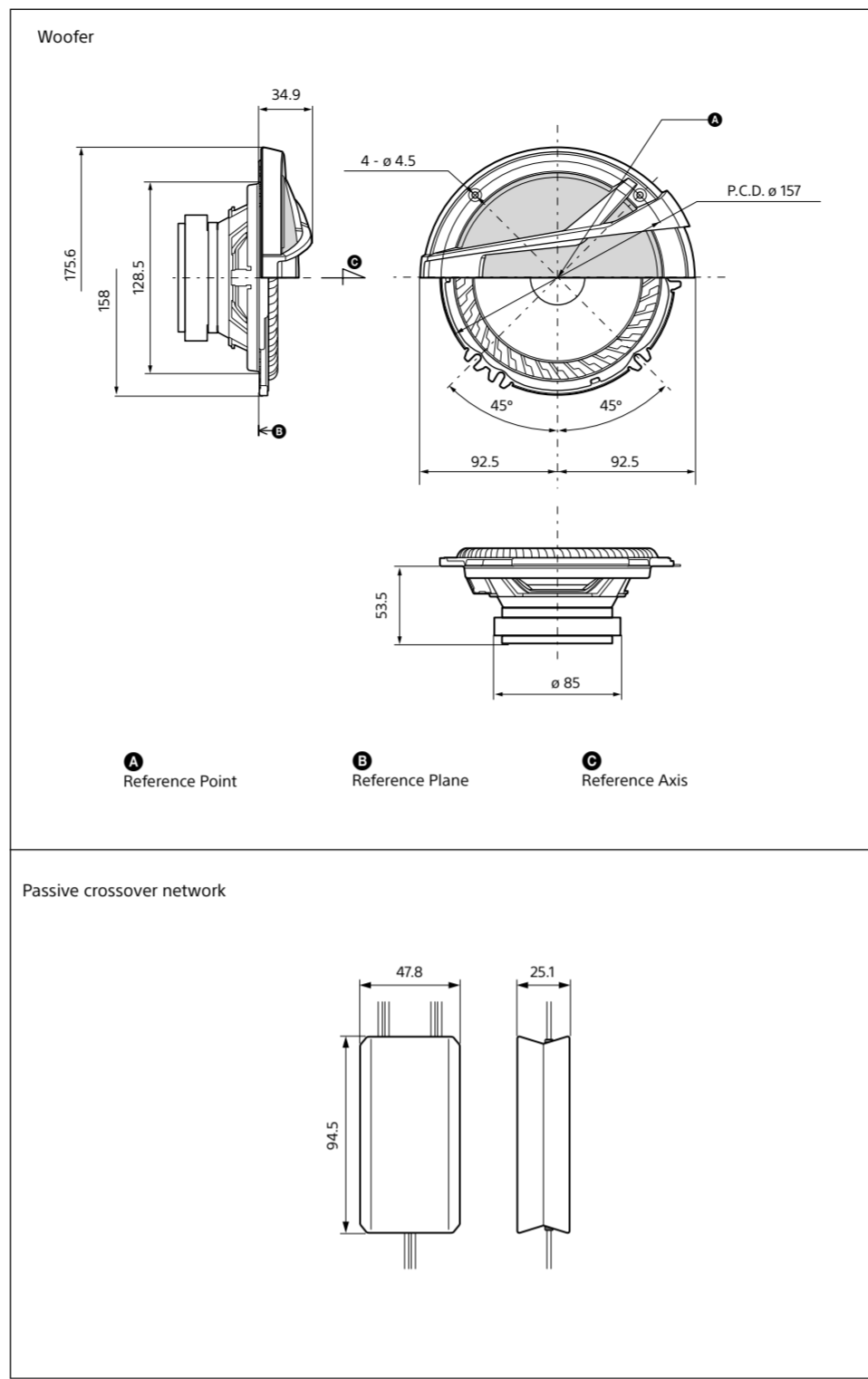

## Precautions

- Do not continuously use the speaker system beyond the peak power handling capacity.
- Keep recorded tapes, watches, and personal credit cards using magnetic coding away from the speaker system to protect them from damage caused by the magnets in the speakers.
- Please note the following when installing the units; otherwise malfunction and/or deterioration in sound quality may result.
  - Do not touch the diaphragms and/or speaker cones by hand or with tools.
  - Do not put your fingers through the holes of the frame.
  - Do not drop foreign objects in the units.

### Caution

When using the speakers with an amplifier or power booster employing the BTL (balanced transformerless) system, **be sure to connect the speaker system cords directly to the amplifier speaker cords.** If the connection is made through already existing speaker cords which have a common ⊖ lead for both the right and left channels, it is possible that no sound will be heard, and that the amplifier will be damaged.

If you cannot find an appropriate mounting location, consult your car dealer or your nearest Sony dealer before mounting.

## Specifications

Speaker:	Separate type, 2 way: Woofer 16 cm cone type Tweeter 2.5 cm dome type
Short-term Maximum Power*1:	350 W*2
Rated power:	60 W*2
CTA 2031 RMS Power:	60 W
Rated impedance:	4 Ω
Output sound pressure level:	87±2 dB (1 W, 1 m)*2
Effective frequency range:	55 – 30,000 Hz*2
Mass:	Woofer: Approx. 850 g per speaker Tweeter: Approx. 80 g per speaker Passive crossover network: Approx. 110 g per box
Supplied accessories	Parts for installation

Design and specifications are subject to change without notice.

\*1 "Short-term Maximum Power" may also be referred to as "Peak Power."

\*2 Testing Condition: IEC 60268-5 (2003-05)

# Mounting

## Before mounting

A depth of at least 53.5 mm is required to mount the woofer. Measure the depth of the area where you are to mount the speaker, and ensure that the speaker is not obstructing any other components of the car. Keep the following in mind when choosing a mounting location:

- Make sure that nothing is obstructing around the mounting location of the door (front or rear) where you are to mount the speaker.
- A hole for mounting may already be cut out of the inner panel of the door (front or rear). In this case, you need to modify the board only.
- If you are to mount this speaker system in the door (front or rear), make sure that the speaker terminals, frame or magnet do not interfere with any inner parts, such as the window mechanism in the door (when you open or close the window), etc. Also make sure that the speaker grille does not touch any inner fittings, such as the window cranks, door handles, arm rests, door pockets, lamps or seats etc.
- The suitable mounting location for the tweeters varies depending on the type of car. Choose a location that suits your car.

©2016 Sony Corporation Printed in Vietnam

XS-XB1621C

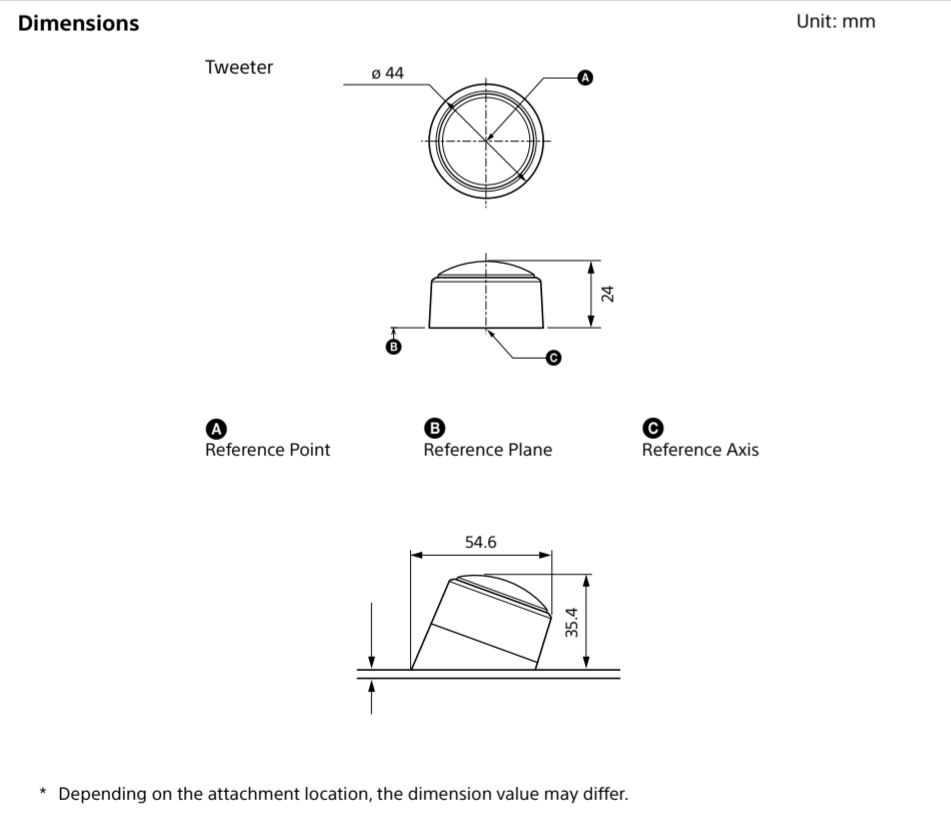

## Connections

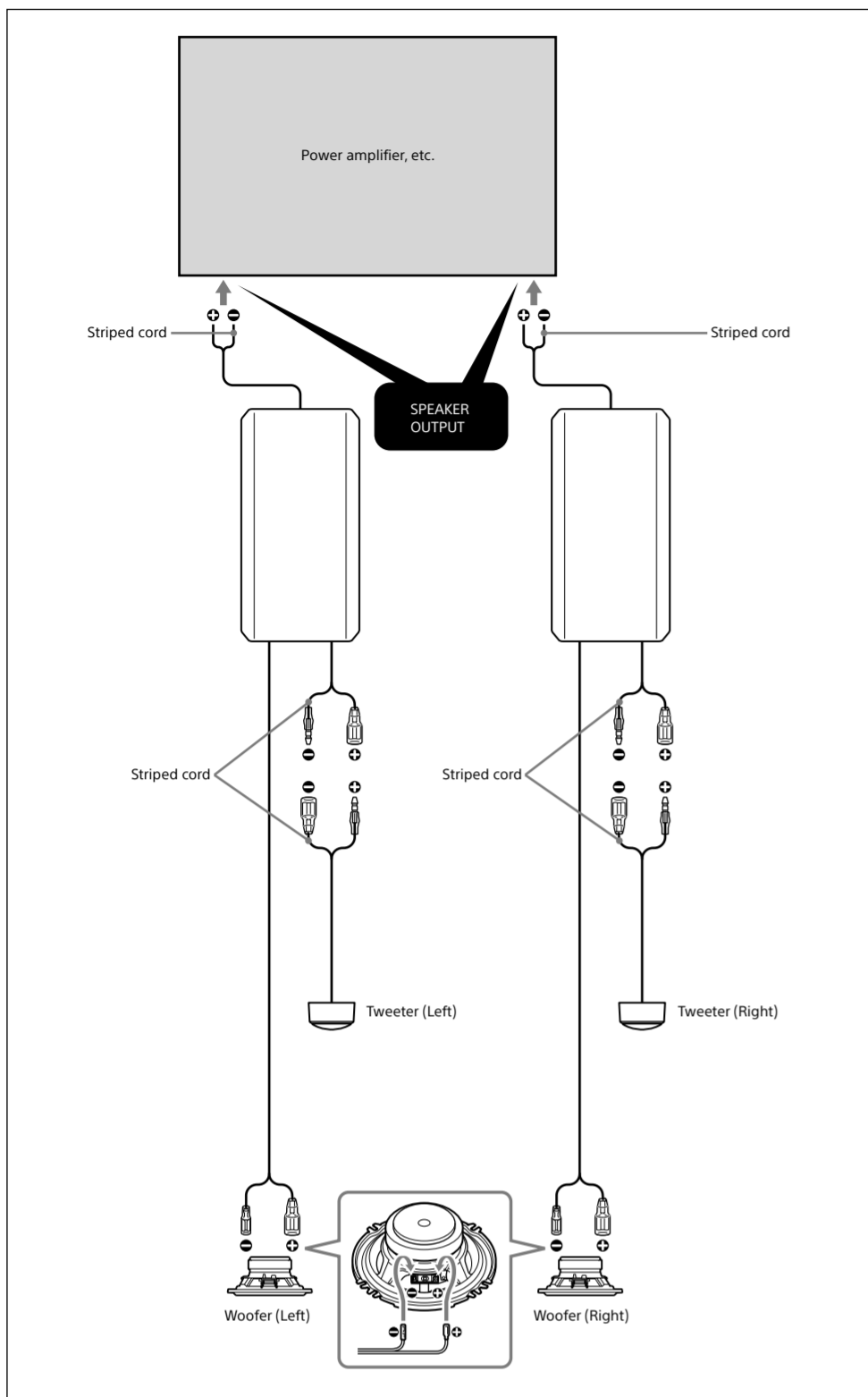

## Parts list

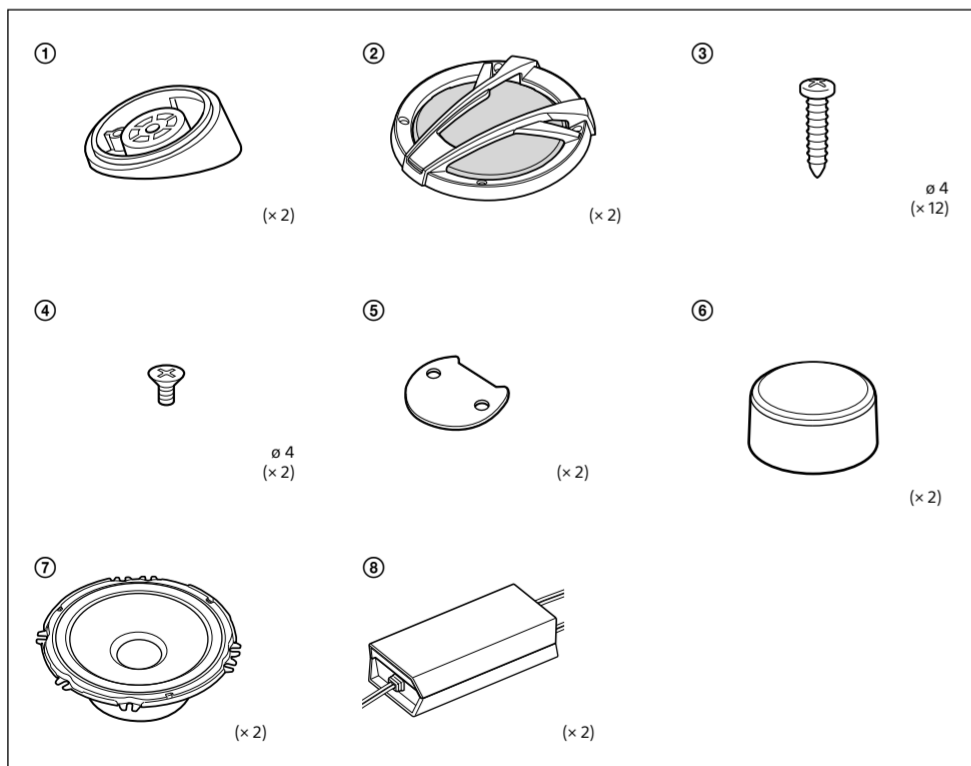

## Tweeter

### Example

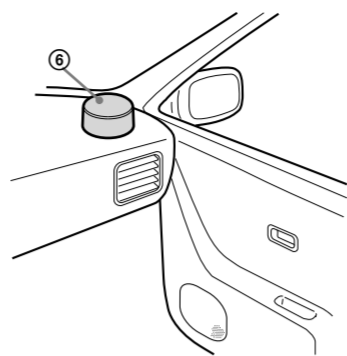

### 1 Remove the inside door panel.

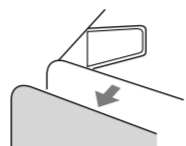

### 2

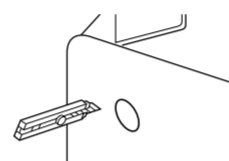
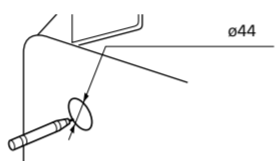

Unit: mm

Decide the method to mount the unit depending on the type of the car and the installation location.

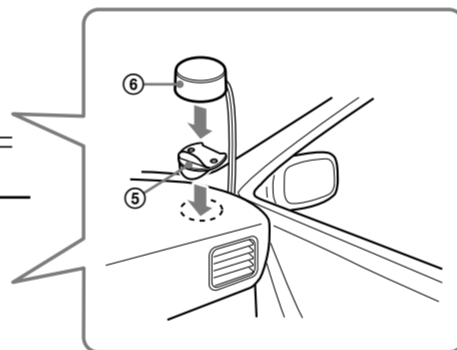
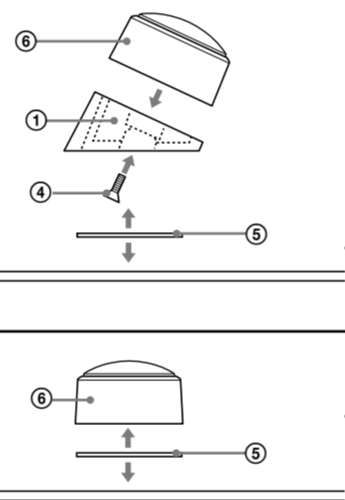

## Woofers

### 1 Mark the 4 bolt holes and make them 3.2 mm in diameter.

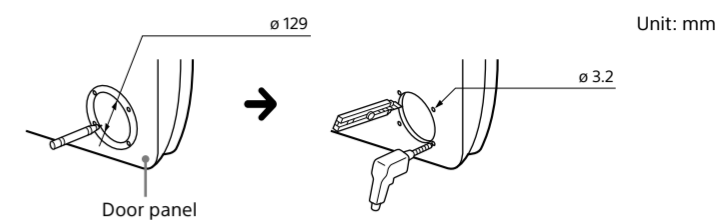

### 2

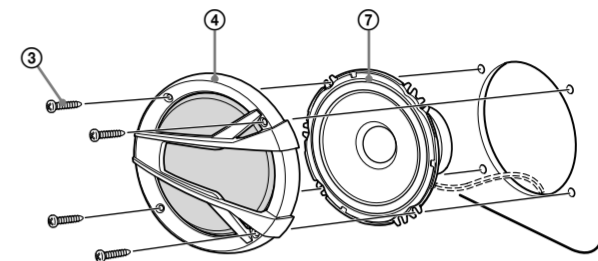

## Passive crossover network

Remove the connection box cover by hand.

