

# TOOLPRO

## 18V Li-Ion Brushless Impact wrench

Instruction Manual

CIW180HB.9

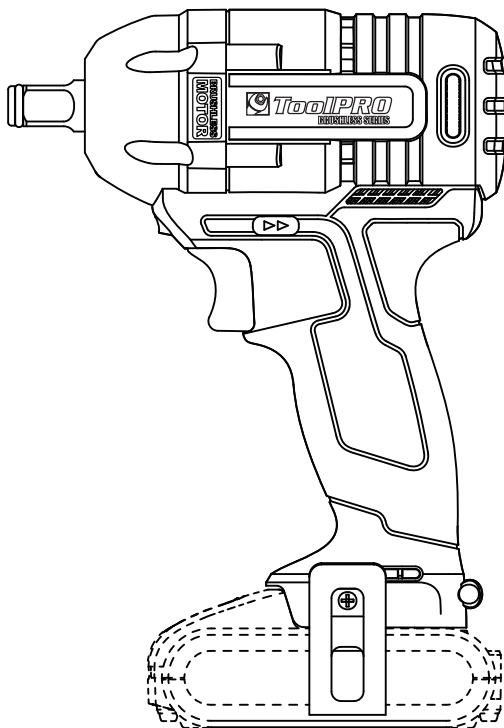

# ToolPRO

### After Sales Support

FREE CALL 1300 889 028  
EMAIL: [salesau@positecgroup.com](mailto:salesau@positecgroup.com)

**Important** - Please read these instructions fully before operating or maintaining your Brushless Impact wrench

These instructions contain important information that will help you get the best from your Brushless Impact wrench, ensuring it remains safe to operate.

If you need help or have damaged or missing parts, call the Customer Helpline on 1300 889 028

# Contents

<b>Safety Information</b> .....	<b>3</b>
<b>In The Box</b> .....	<b>8</b>
<b>Accessories</b> .....	<b>8</b>
<b>Operating Instructions</b> .....	<b>9</b>
<b>Problem solution</b> .....	<b>14</b>
<b>Maintenance</b> .....	<b>15</b>
<b>Technical Data</b> .....	<b>15</b>

# Safety Information

**Important** - Please read these instructions fully before starting assembly

## Warning Symbols



To reduce the risk of injury, Please read the instruction manual



Warning



Wear ear protection



Wear eye protection



Wear dust mask



Indoor use only



Do not expose to rain or water



Do not burn



Waste electrical products must not be disposed of with household waste. Please recycle where facilities exist. Check with your local authorities or retailer for recycling advice.



Li-Ion



Li-Ion

Li-ion battery. This product has been marked with a symbol relating to 'separate collection' for all battery packs and battery pack. It will then be recycled or dismantled in order to reduce the impact on the environment. Battery packs can be hazardous for the environment and for human health since they contain hazardous substances.



Fuse



Positive terminal



Negative terminal



Read the operator's manual



Double insulation



RCM marking

**ABN:** Australian Business Number. By this number, business information such as entity type, status, business location etc. can be found at website <http://abr.business.gov.au>.  
ABN of Positec Australia Pty Limited is 14 101 682 357

# Safety Information

**Important** - Please read these instructions fully before starting assembly

## General Power Tool Safety Warnings



**WARNING!** Read all safety warnings and all instructions. Failure to follow the warnings and instructions may result in electric shock, fire and/or serious injury.

### Save all warnings and instructions for future reference.

The term "power tool" in the warnings refers to your mains-operated (corded) power tool or battery-operated (cordless) power tool.

#### 1) Work area safety

- a) **Keep work area clean and well lit.** Cluttered or dark areas invite accidents.
- b) **Do not operate power tools in explosive atmospheres, such as in the presence of flammable liquids, gases or dust.** Power tools create sparks which may ignite the dust or fumes.
- c) **Keep children and bystanders away while operating a power tool.** Distractions can cause you to lose control.

#### 2) Electrical safety

- a) **Power tool plugs must match the outlet. Never modify the plug in any way. Do not use any adapter plugs with earthed (grounded) power tools.** Unmodified plugs and matching outlets will reduce risk of electric shock.
- b) **Avoid body contact with earthed or grounded surfaces, such as pipes, radiators, ranges and refrigerators.** There is an increased risk of electric shock if your body is earthed or grounded.
- c) **Do not expose power tools to rain or wet conditions.** Water entering a power tool will increase the risk of electric shock.
- d) **Do not abuse the cord. Never use the cord for carrying, pulling or unplugging the power tool. Keep cord away from heat, oil, sharp edges or moving parts.** Damaged or entangled cords increase the risk of electric shock.
- e) **When operating a power tool outdoors, use an extension cord suitable for outdoor use.** Use of a cord suitable for outdoor use reduces the risk of electric shock.
- f) **If operating a power tool in a damp location is unavoidable, use a residual current device (RCD) protected supply.** Use of an RCD reduces the risk of electric shock.

#### 3) Personal safety

- a) **Stay alert, watch what you are doing and use common sense when operating a power tool. Do not use a power tool while you are tired or under the influence of drugs, alcohol or medication.** A moment of inattention while operating power tools may result in serious personal injury.
- b) **Use personal protective equipment. Always wear eye protection.** Protective equipment such as dust mask, non-skid safety shoes, hard hat, or hearing protection used for appropriate conditions will reduce personal injuries.
- c) **Prevent unintentional starting. Ensure the switch is in the off-position before connecting to power source and/or battery pack, picking up or carrying the tool.** Carrying power tools with your finger on the switch or energising power tools that have the switch on invites accidents.

# Safety Information

**Important** - Please read these instructions fully before starting assembly

## General Power Tool Safety Warnings

- d) **Remove any adjusting key or wrench before turning the power tool on.** A wrench or a key left attached to a rotating part of the power tool may result in personal injury.
- e) **Do not overreach. Keep proper footing and balance at all times.** This enables better control of the power tool in unexpected situations.
- f) **Dress properly. Do not wear loose clothing or jewellery. Keep your hair, clothing and gloves away from moving parts.** Loose clothes, jewellery or long hair can be caught in moving parts.
- g) **If devices are provided for the connection of dust extraction and collection facilities, ensure these are connected and properly used.** Use of dust collection can reduce dust-related hazards.

### 4) Power tool use and care

- a) **Do not force the power tool. Use the correct power tool for your application.**  
The correct power tool will do the job better and safer at the rate for which it was designed.
- b) **Do not use the power tool if the switch does not turn it on and off.** Any power tool that cannot be controlled with the switch is dangerous and must be repaired.
- c) **Disconnect the plug from the power source and/or the battery pack from the power tool before making any adjustments, changing accessories, or storing power tools.** Such preventive safety measures reduce the risk of starting the power tool accidentally.
- d) **Store idle power tools out of the reach of children and do not allow persons unfamiliar with the power tool or these instructions to operate the power tool.**  
Power tools are dangerous in the hands of untrained users.
- e) **Maintain power tools. Check for misalignment or binding of moving parts, breakage of parts and any other condition that may affect the power tool's operation. If damaged, have the power tool repaired before use.** Many accidents are caused by poorly maintained power tools.
- f) **Keep cutting tools sharp and clean.** Properly maintained cutting tools with sharp cutting edges are less likely to bind and are easier to control.
- g) **Use the power tool, accessories and tool bits etc. in accordance with these instructions, taking into account the working conditions and the work to be performed.** Use of the power tool for operations different from those intended could result in a hazardous situation.

### 5) Battery tool use and care

- a) **Recharge only with the charger specified by the manufacturer.** A charger that is suitable for one type of battery pack may create a risk of fire when used with another battery pack.
- b) **Use power tools only with specifically designated battery packs.** Use of any other battery packs may create a risk of injury and fire.
- c) **When battery pack is not in use, keep it away from other metal objects, like paper clips, coins, keys, nails, screws or other small metal objects, that can make a connection from one terminal to another.** Shorting the battery terminals together may cause burns or a fire.

# Safety Information

**Important** - Please read these instructions fully before starting assembly

## General Power Tool Safety Warnings

- d) **Under abusive conditions, liquid may be ejected from the battery; avoid contact.** If contact accidentally occurs, flush with water. If liquid contacts eyes, additionally seek medical help. Liquid ejected from the battery may cause irritation or burns.
- 6) **Service**  
Have your power tool serviced by a qualified repair person using only identical replacement parts. This will ensure that the safety of the power tool is maintained.

## Screwdriver and impact wrench safety warning

- 1. **Hold power tool by insulated gripping surfaces, when performing an operation where the fastener may contact hidden wiring. Fasteners contacting a “live” wire may make exposed metal parts of the power tool “live” and could give the operator an electric shock.**

## Safety Warnings for battery pack

- a) **Do not dismantle, open or shred cells or battery pack.**
- b) **Do not short-circuit a battery pack. Do not store battery packs haphazardly in a box or drawer where they may short-circuit each other or be short-circuited by conductive materials.** When battery pack is not in use, keep it away from other metal objects, like paper clips, coins, keys, nails, screws or other small metal objects, that can make a connection from one terminal to another. Shorting the battery terminals together may cause burns or a fire.
- c) **Do not expose battery pack to heat or fire. Avoid storage in direct sunlight.**
- d) **Do not subject battery pack to mechanical shock.**
- e) **In the event of battery leaking, do not allow the liquid to come into contact with the skin or eyes.** If contact has been made, wash the affected area with copious amounts of water and seek medical advice.
- f) **Seek medical advice immediately if a cell or battery pack has been swallowed.**
- g) **Keep battery pack clean and dry.**
- h) **Wipe the battery pack terminals with a clean dry cloth if they become dirty.**
- i) **Battery pack needs to be charged before use. Always refer to this instruction and use the correct charging procedure.**
- j) **Do not maintain battery pack on charge when not in use.**
- k) **After extended periods of storage, it may be necessary to charge and discharge the battery pack several times to obtain maximum performance.**
- l) **Battery pack gives its best performance when it is operated at normal room temperature (20 °C ± 5 °C).**
- m) **When disposing of battery packs, keep battery packs of different electrochemical systems separate from each other.**
- n) **Recharge only with the charger specified by manufacturer.** Do not use any charger other than that specifically provided for use with the equipment. A charger that is suitable for one type of battery pack may create a risk of fire when used with another battery pack.
- o) **Do not use any battery pack which is not designed for use with the equipment.**
- p) **Keep battery pack out of the reach of children.**
- q) **Retain the original product literature for future reference.**
- r) **Remove the battery from the equipment when not in use.**
- s) **Dispose of properly.**

# Safety Information

**Important** - Please read these instructions fully before starting assembly

## **General Safety Warnings**



**WARNING: Read all safety warnings and all instructions.** Failure to follow the warnings and instructions may result in electric shock, fire and/or serious injury.

**Save all warnings and instructions for future reference.**

- This appliance is not intended for use by persons (including children) with reduced physical, sensory or mental capabilities, or lack of experience and knowledge, unless they have been given supervision or instruction concerning use of the appliance by a person responsible for their safety.

- Children should be supervised to ensure that they do not play with the appliance.

If the supply cord is damaged, it must be replaced by the manufacturer, its service agent or similarly qualified persons in order to avoid a hazard.

### **Additional safety instructions for your Battery Charger**

1. Before charging, read the instructions.
2. For charge Li-ion battery pack only.
3. If the supply cord is damaged, it must be replaced by the manufacturer, its service agent or similarly qualified persons in order to avoid a hazard.
4. The battery terminal not connected to the chassis has to be connected first. The other connection is to be made to the chassis, remote from the battery and fuel line. The battery charger is then to be connected to the supply mains.
5. After charging, disconnect the battery charger from the supply mains. Then remove the chassis connection and then the battery connection.
6. Do not charge a leaking battery.
7. Do not use chargers for works other than those for which they are designed.
8. Before charging, ensure your charger is matching the local AC supply.
9. The charging device must be protected from moisture.
10. Do not use the charging device in the open.
11. Do not short out the contacts of battery or charger.
12. Respect the polarity "+/-" when charging.
13. Do not open the unit and keep out of the reach of children.
14. Ensure that the connection between the battery charger and battery is correctly positioned and is not obstructed by foreign bodies.
15. Keep battery charger's slots free of foreign objects and protect against dirt and humidity. Store in a dry and frost-free place.
16. When charging batteries, ensure that the battery charger is in a well-ventilated area and away from inflammable materials. Batteries can get hot during charging. Do not overcharge any batteries. Ensure that batteries and chargers are not left unsupervised during charging.
17. Do not recharge non-rechargeable batteries, as they can overheat and break.
18. Longer life and better performance can be obtained if the battery pack is charged when the air temperature is between 18°C and 24°C. Do not charge the battery pack in air temperatures below 4.5°C, or above 40.5°C. This is important as it can prevent serious damage to the battery pack.
19. Charge only battery pack of the same model provided by manufacturer and of models recommended by manufacturer.

# In The Box

## Parts

- ① Forward, Reverse Rotation And Lock Control
- ② Battery Pack\*
- ③ Battery Pack Release Button\*
- ④ Belt Clip
- ⑤ On/Off Switch With Variable Speed Control
- ⑥ Led Light
- ⑦ Tool Holder

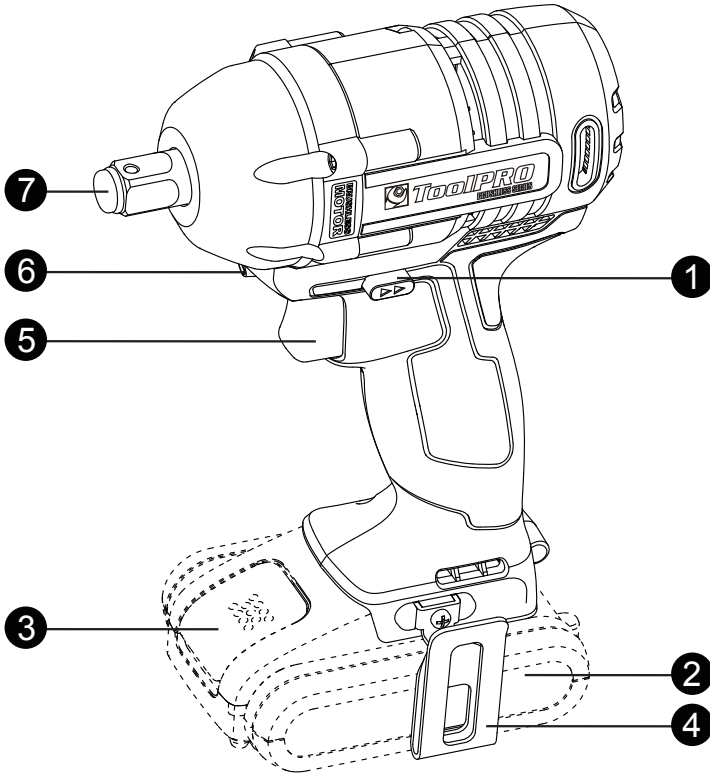

# Accessories

Belt clip

1



# Operating Instructions



**NOTE: Before using the tool, read the instruction book carefully.**

## **Intended Use**

This tool is intended for the fastening and loosening of bolts, nuts and various threaded fasteners. This tool is not intended for use as a drill, Please check manually to ensure safety after fastening, and we recommend tightening to manufactures specifications.

## **1. CHARGING**

**We strongly recommend to use ToolPRO battery & charger kit. Please contact you local Supercheap Auto store for more details or log onto [www.supercheapauto.com.au](http://www.supercheapauto.com.au) for Australia or [www.supercheapauto.co.nz](http://www.supercheapauto.co.nz) for New Zealand customers to find out more details.**

### **BEFORE PUTTING INTO OPERATION**

#### **CHARGING THE BATTERY PACK (SEE FIG. A)**

##### **NOTE:**

- a) **The battery in your new tool is not charged when it leaves the plant. Therefore it must be full charged before using the first time.**
- b) Do not use any charger other than that specifically provided for use with the equipment.
- c) If the battery pack is very hot you must remove your battery pack from the charger and allow time for the battery to cool down before recharging.
- d) Please charge the battery to reach full or no less than half charge before storage. If the tool will not be used for long periods of time, charge the battery every 3-6 months.

### **CHARGING PROCEDURE**

- 1) Plug the charger into an appropriate outlet.
- 2) Place the battery pack into the charger
- 3) When charging is completed, unplug the charger and remove the battery pack.

**Note: If the battery pack is locked in the charger, press the battery pack release button and remove it.**







**WARNING: When battery charge runs out after continuous use or exposure to direct sunlight or heat, allow time for the tool to cool down before re-charging to achieve the full charge.**



# Operating Instructions

## CHARGING INDICATOR

### 1. Fast charger(See fig. A1)

Light	ON/OFF flash	Status
Red on 	————	Charging
Red flash 	- - - - -	Defective Battery
Green on 	————	Fully Charged
Green flash 	- - - - -	Hot/Cold Delay

### 2. Slow charger(See fig. A2)

Light	ON/OFF flash	Status
Green flash 	- - - - -	Charging
Green on 	————	Fully Charged

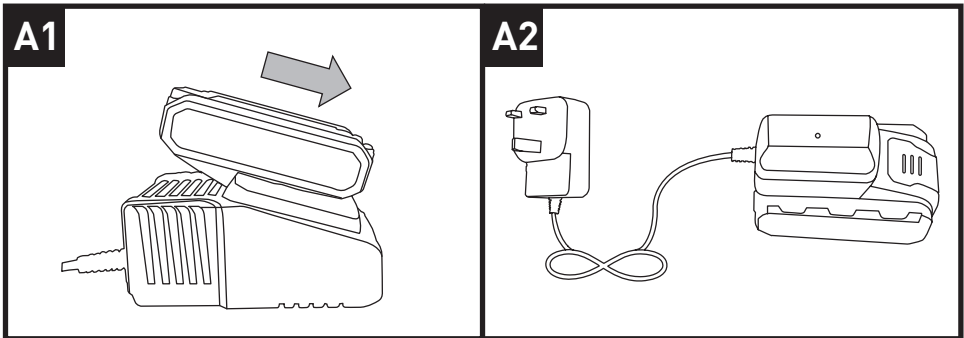

# Operating Instructions

## 2. INSTALLING AND REMOVING THE BATTERY PACK(not supplied)

### a) TO REMOVE THE BATTERY PACK (SEE FIG B1)

Press the Battery Pack Release Button firmly first and then slide the Battery Pack out from your tool.

### b) TO INSTALL THE BATTERY PACK (SEE FIG B2)

Slide the fully charged Battery Pack onto the tool with sufficient force until it clicks into position.

## OPERATION

### 1. HOW TO USE THE BELT HOOK (See Fig. C1&C2)

Screw the Belt Hook on the tool with the screw provided in the plastic bag. The Belt Hook can be hooked on your belt or pocket, etc.

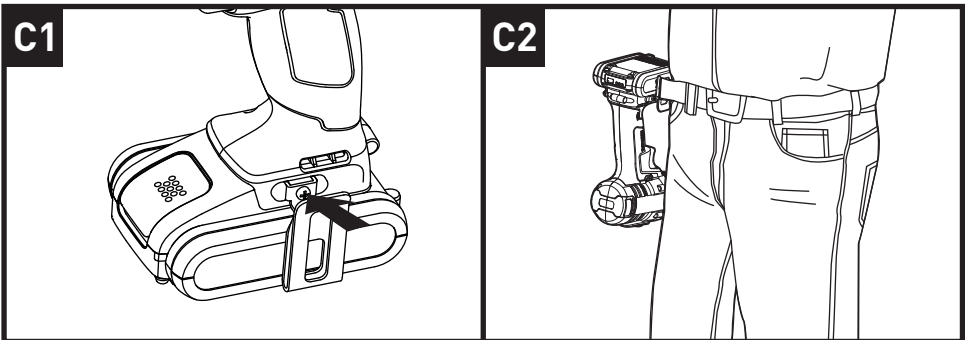
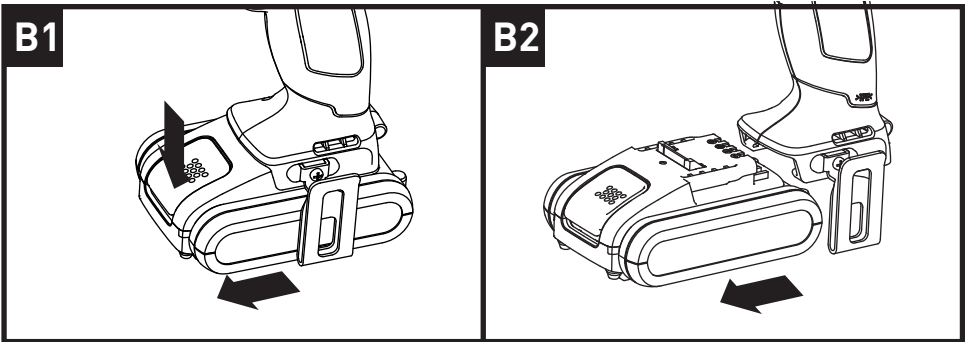

# Operating Instructions

## 2. TO INSTALL OR REMOVE SOCKET ON THE TOOL HOLDER (See Fig. D)

To install the socket (a) (not supplied), insert the socket onto the tool holder.  
To remove the socket (a), pull the socket out of the tool holder.



**WARNING: Inspect tool holders and socket carefully before using the tool. Missing or damaged items should be replaced. Make sure the switch is locked off or remove the battery pack before changing accessories.**

## 3. FORWARD, REVERSE ROTATION AND LOCK CONTROL (See Fig. E1&E2)

Your tool is equipped with a forward, reverse rotation and lock control located above the on/off switch. It was designed for changing rotation of the chuck and for locking the on/off switch in the center position to help prevent accidental start and accidental battery discharge.

For forward rotation, (with chuck pointed away from you) move the lever to the far left. For reverse rotation move the lever to the far right. To activate switch lock move the lever to the center off position.



**CAUTION: Do not change direction of rotation until the tool comes to a complete stop. Shifting during rotation of the chuck can cause damage to the tool.**

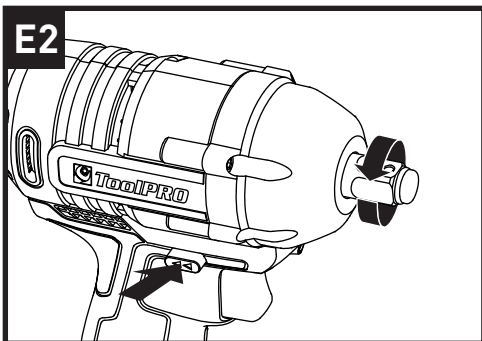
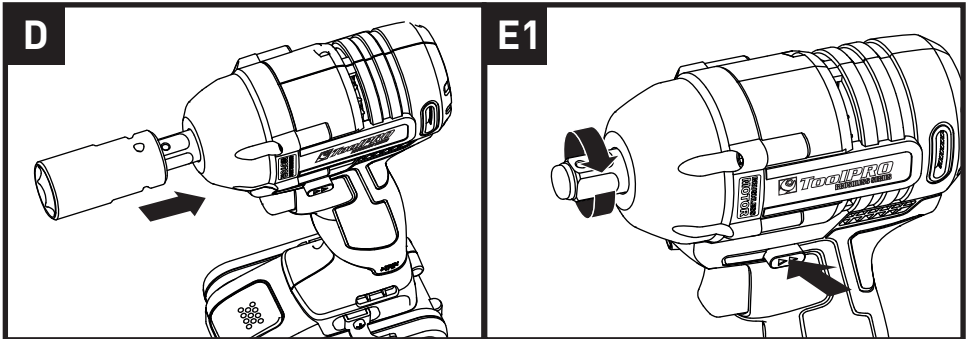

# Operating Instructions

## **4. USING THE LED LIGHT**

The LED light allows you to keep a clear view under less illuminated circumstances. To turn on the light simply press the on/off switch. When you release the on/off switch, the light will be off.

## **5. OVERLOAD PROTECTION**

When overloaded, the motor comes to a stop. Relieve the load on the machine immediately and allow cooling for approx. 30 seconds at the highest no-load speed.

## **6. TEMPERATURE DEPENDENT OVERLOAD PROTECTION**

When using as intended for the power tool cannot be subject to overload. When the load is too high or the allowable battery temperature of 75°C is exceeded, the electronic control switches off the power tool until the temperature is in the optimum temperature range again.

## **7. PROTECTION AGAINST DEEP DISCHARGING**

The Li-ion battery is protected against deep discharging by the "Discharging Protection System". When the battery is empty, the machine is switched off by means of a protective circuit: The inserted tool no longer rotates.

# Problem solution

## **1. WHY DOES THE IMPACT DRIVER NOT TURN ON WHEN YOU PRESS THE SWITCH?**

The forward/reverse rotation control, which is on top of the trigger, is positioned in the lock function. Unlock the forward/reverse rotation control by putting it into the required rotation position. Push the trigger and the impact driver will start to rotate.

## **2. REASONS FOR DIFFERENT BATTERY PACK WORKING TIMES**

Charging time problems, as above, and having not used a battery pack for a prolonged time will reduce the battery pack working time. This can be corrected after several charge and discharge operations by charging & working with your drill. Heavy working conditions such as large screws into hard wood will use up the battery pack energy faster than lighter working conditions. Do not recharge your battery pack below 0°C and above 45°C as this will affect performance.

# Maintenance





**Remove the battery pack from the tool before carrying out any adjustment, servicing or maintenance.**

Your power tool requires no additional lubrication or maintenance.

There are no user serviceable parts in your power tool. Never use water or chemical cleaners to clean your power tool. Wipe clean with a dry cloth. Always store your power tool in a dry place. Keep the motor ventilation slots clean. Keep all working controls free of dust. Occasionally you may see sparks through the ventilation slots. This is normal and will not damage your power tool.

# Technical Data

## Technical Data Table

Voltage	18 V 
No load speed	0-2200 /min
Impact rate	0-3000/min
Max torque	200 N.m
Chuck Size	1/2"
Battery capacity	Lithium Battery
Machine weight	1.40kg (Including battery)
Charger Protection class	
Charging time	1-1.5hr by fast charger, 3-5hrs by slow charger
Charger Input	100-240V~50/60Hz
Charger Output	10.8-20V  1.5A by fast charger 10.8-20V  400mA by slow charger
Battery capacity	1.5/2.0Ah Li-ion battery

**Staple your purchase receipt here  
Before returning this product for  
warranty or any other reason, please call.  
POSITEC AUSTRALIA PTY LIMITED  
ABN 14 101 682 357  
Unit 15, 23 Narabang Way Belrose 2085 NSW Australia  
FREE CALL 1300 889 028  
EMAIL:salesau@positecgroup.com**



