

STANLEY®

FATMAX®

EN

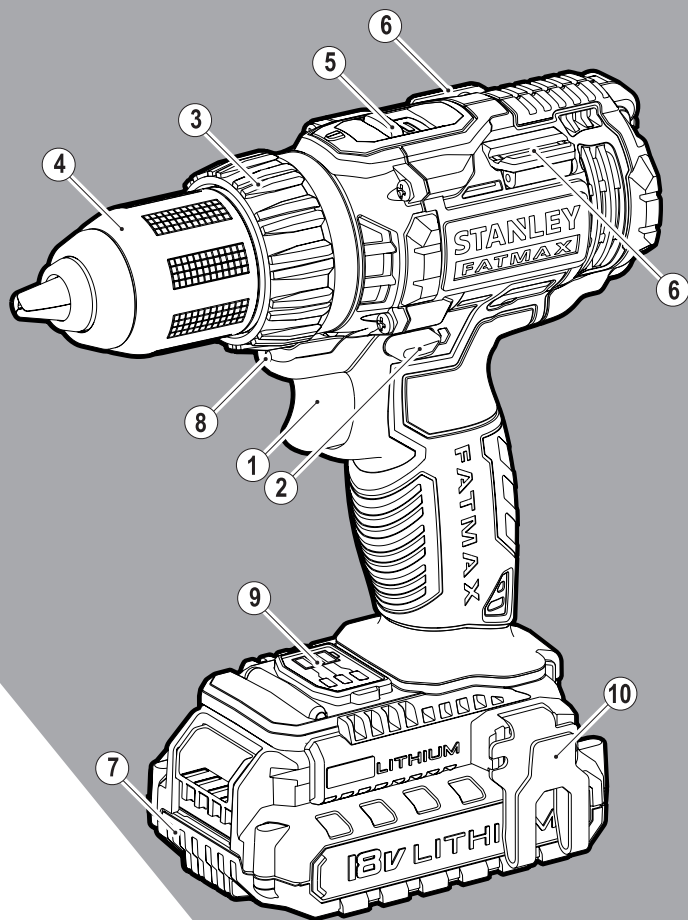

FMC600

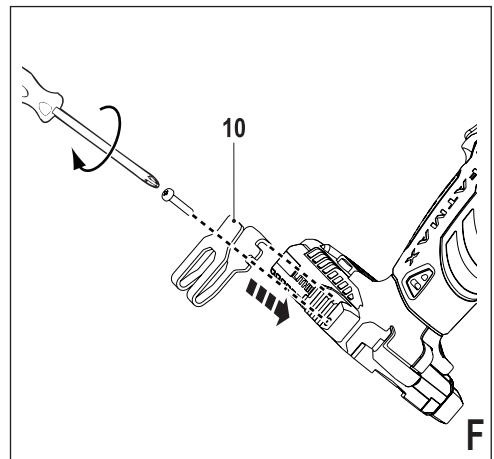
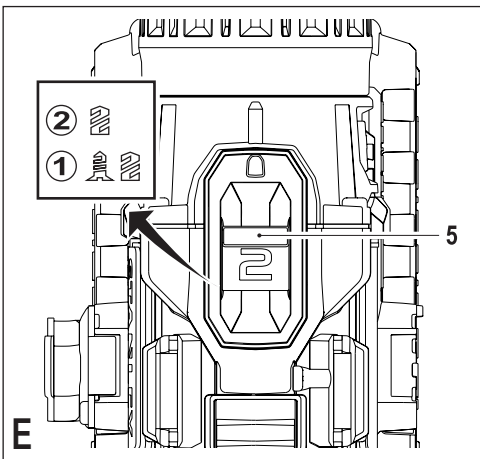
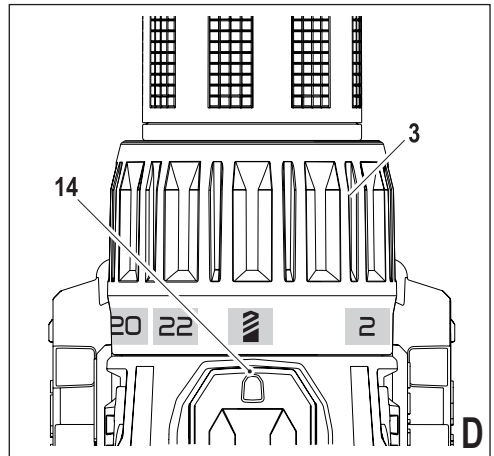
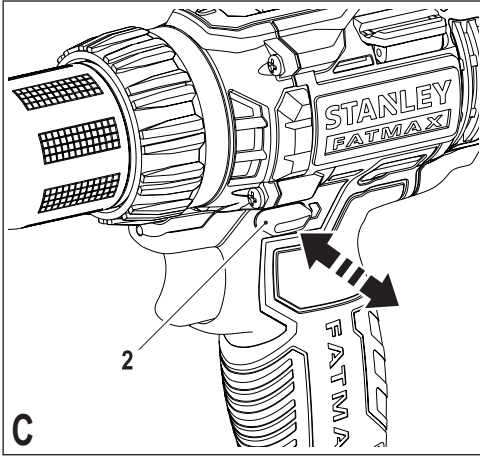
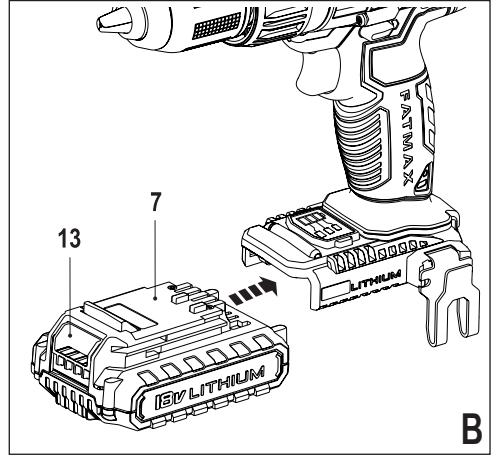
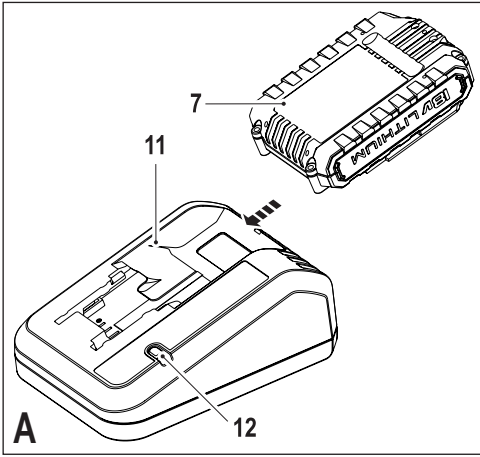

Intended use

Your Stanley FatMax drill/screwdriver has been designed for screwdriving applications and for drilling in wood, metal and plastics. This tool is intended for professional and private, non professional users.

Safety instructions

General power tool safety warnings



Warning! Read all safety warnings and all instructions. Failure to follow the warnings and instructions listed below may result in electric shock, fire and/or serious injury.

Save all warnings and instructions for future reference.

The term "power tool" in all of the warnings listed below refers to your mains operated (corded) power tool or battery operated (cordless) power tool.

1. Work area safety

- a. **Keep work area clean and well lit.** Cluttered or dark areas invite accidents.
- b. **Do not operate power tools in explosive atmospheres, such as in the presence of flammable liquids, gases or dust.** Power tools create sparks which may ignite the dust or fumes.
- c. **Keep children and bystanders away while operating a power tool.** Distractions can cause you to lose control.

2. Electrical safety

- a. **Power tool plugs must match the outlet. Never modify the plug in any way. Do not use any adapter plugs with earthed (grounded) power tools.** Unmodified plugs and matching outlets will reduce risk of electric shock.
- b. **Avoid body contact with earthed or grounded surfaces such as pipes, radiators, ranges and refrigerators.** There is an increased risk of electric shock if your body is earthed or grounded.
- c. **Do not expose power tools to rain or wet conditions.** Water entering a power tool will increase the risk of electric shock.
- d. **Do not abuse the cord. Never use the cord for carrying, pulling or unplugging the power tool. Keep cord away from heat, oil, sharp edges or moving parts.** Damaged or entangled cords increase the risk of electric shock.
- e. **When operating a power tool outdoors, use an extension cord suitable for outdoor use.** Use of a cord suitable for outdoor use reduces the risk of electric shock.

- f. **If operating a power tool in a damp location is unavoidable, use a residual current device (RCD) protected supply.** Use of an RCD reduces the risk of electric shock.
- ### 3. Personal safety
- a. **Stay alert, watch what you are doing and use common sense when operating a power tool. Do not use a power tool while you are tired or under the influence of drugs, alcohol or medication.** A moment of inattention while operating power tools may result in serious personal injury.
 - b. **Use personal protective equipment. Always wear eye protection.** Protective equipment such as dust mask, non-skid safety shoes, hard hat, or hearing protection used for appropriate conditions will reduce personal injuries.
 - c. **Prevent unintentional starting. Ensure the switch is in the off-position before connecting to power source and/or battery pack, picking up or carrying the tool.** Carrying power tools with your finger on the switch or energising power tools that have the switch on invites accidents.
 - d. **Remove any adjusting key or wrench before turning the power tool on.** A wrench or a key left attached to a rotating part of the power tool may result in personal injury.
 - e. **Do not overreach. Keep proper footing and balance at all times.** This enables better control of the power tool in unexpected situations.
 - f. **Dress properly. Do not wear loose clothing or jewellery. Keep your hair, clothing and gloves away from moving parts.** Loose clothes, jewellery or long hair can be caught in moving parts.
 - g. **If devices are provided for the connection of dust extraction and collection facilities, ensure these are connected and properly used.** Use of dust collection can reduce dust-related hazards.
- ### 4. Power tool use and care
- a. **Do not force the power tool. Use the correct power tool for your application.** The correct power tool will do the job better and safer at the rate for which it was designed.
 - b. **Do not use the power tool if the switch does not turn it on and off.** Any power tool that cannot be controlled with the switch is dangerous and must be repaired.
 - c. **Disconnect the plug from the power source and/or the battery pack from the power tool before making any adjustments, changing accessories, or storing power tools.** Such preventive safety measures reduce the risk of starting the power tool accidentally.

- d. **Store idle power tools out of the reach of children and do not allow persons unfamiliar with the power tool or these instructions to operate the power tool.** Power tools are dangerous in the hands of untrained users.
 - e. **Maintain power tools. Check for misalignment or binding of moving parts, breakage of parts and any other condition that may affect the power tools operation. If damaged, have the power tool repaired before use.** Many accidents are caused by poorly maintained power tools.
 - f. **Keep cutting tools sharp and clean.** Properly maintained cutting tools with sharp cutting edges are less likely to bind and are easier to control.
 - g. **Use the power tool, accessories and tool bits etc. in accordance with these instructions, taking into account the working conditions and the work to be performed.** Use of the power tool for operations different from those intended could result in a hazardous situation.
5. **Battery tool use and care**
 - a. **Recharge only with the charger specified by the manufacturer.** A charger that is suitable for one type of battery pack may create a risk of fire when used with another battery pack.
 - b. **Use power tools only with specifically designated battery packs.** Use of any other battery packs may create a risk of injury and fire.
 - c. **When battery pack is not in use, keep it away from other metal objects, like paper clips, coins, keys, nails, screws, or other small metal objects, that can make a connection from one terminal to another.** Shorting the battery terminals together may cause burns or a fire.
 - d. **Under abusive conditions, liquid may be ejected from the battery; avoid contact. If contact accidentally occurs, flush with water. If liquid contacts eyes, additionally seek medical help.** Liquid ejected from the battery may cause irritation or burns.
 6. **Service**
 - a. **Have your power tool serviced by a qualified repair person using only identical replacement parts.** This will ensure that the safety of the power tool is maintained.
 - b. **Power to the tool should always be supplied via residual current device with a rated residual current of 30mA or less.**
- ◆ **Wear ear protectors when impact drilling.** Exposure to noise can cause hearing loss.
 - ◆ **Use auxiliary handle(s) if supplied with the tool.** Loss of control can cause personal injury.
 - ◆ **Hold power tool by insulated gripping surfaces when performing an operation where the cutting accessory may contact hidden wiring.** Cutting accessory contacting a "live" wire may make exposed metal parts of the power tool "live" and could give the operator an electric shock.
 - ◆ **Hold power tool by insulated gripping surfaces when performing an operation where the fastener may contact hidden wiring.** Fasteners contacting a "live" wire may make exposed metal parts of the power tool "live" and could give the operator an electric shock
 - ◆ **Use clamps or another practical way to secure and support the workpiece to a stable platform.** Holding the work by hand or against your body leaves it unstable and may lead to loss of control.
 - ◆ Before drilling into walls, floors or ceilings, check for the location of wiring and pipes.
 - ◆ Avoid touching the tip of a drill bit just after drilling, as it may be hot.
 - ◆ This tool is not intended for use by persons (including children) with reduced physical, sensory or mental capabilities, or lack of experience and knowledge, unless they have been given supervision or instruction concerning use of the appliance by a person responsible for their safety. Children should be supervised to ensure that they do not play with the appliance.
 - ◆ The intended use is described in this instruction manual. The use of any accessory or attachment or performance of any operation with this tool other than those recommended in this instruction manual may present a risk of personal injury and/or damage to property.

Vibration

The declared vibration emission values stated in the technical data and the declaration of conformity have been measured in accordance with a standard test method provided by EN 60745 and may be used for comparing one tool with another. The declared vibration emission value may also be used in a preliminary assessment of exposure.

Warning! The vibration emission value during actual use of the power tool can differ from the declared value depending on the ways in which the tool is used. The vibration level may increase above the level stated.

When assessing vibration exposure to determine safety measures required by 2002/44/EC to protect persons regularly using power tools in employment, an estimation of vibration exposure should consider, the actual conditions of use and the



Warning! Additional safety warnings for drills and impact drills

way the tool is used, including taking account of all parts of the operating cycle such as the times when the tool is switched off and when it is running idle in addition to the trigger time.

Residual risks.

Additional residual risks may arise when using the tool which may not be included in the enclosed safety warnings. These risks can arise from misuse, prolonged use etc.

Even with the application of the relevant safety regulations and the implementation of safety devices, certain residual risks can not be avoided. These include:

- ◆ Injuries caused by touching any rotating/moving parts.
- ◆ Injuries caused when changing any parts, blades or accessories.
- ◆ Injuries caused by prolonged use of a tool. When using any tool for prolonged periods ensure you take regular breaks.
- ◆ Impairment of hearing.
- ◆ Health hazards caused by breathing dust developed when using your tool (example:- working with wood, especially oak, beech and MDF.)

Labels on tool

The following pictograms are shown on the tool:



Warning! To reduce the risk of injury, the user must read the instruction manual.

Additional safety instructions for batteries and chargers

Batteries

- ◆ Never attempt to open for any reason.
- ◆ Do not expose the battery to water.
- ◆ Do not store in locations where the temperature may exceed 40 °C.
- ◆ Charge only at ambient temperatures between 10 °C and 40 °C.
- ◆ Charge only using the charger provided with the tool.
- ◆ When disposing of batteries, follow the instructions given in the section "Protecting the environment".



Do not attempt to charge damaged batteries.

Chargers

- ◆ Use your Stanley FatMax charger only to charge the battery in the tool with which it was supplied. Other batteries could burst, causing personal injury and damage.
- ◆ Never attempt to charge non-rechargeable batteries.
- ◆ Have defective cords replaced immediately.

- ◆ Do not expose the charger to water.
- ◆ Do not open the charger.
- ◆ Do not probe the charger.



The charger is intended for indoor use only.



Read the instruction manual before use.

Electrical safety



Your charger is double insulated; therefore no earth wire is required. Always check that the mains voltage corresponds to the voltage on the rating plate. Never attempt to replace the charger unit with a regular mains plug.

- ◆ If the supply cord is damaged, it must be replaced by the manufacturer or an authorised Stanley FatMax Service Centre in order to avoid a hazard.

Features

This tool includes some or all of the following features.

1. Variable speed switch
2. Forward/reverse slider
3. Mode selector / torque adjustment collar
4. Chuck
5. Speed selector
6. Bit holder
7. Battery
8. LED work light
9. State of charge indicator
10. Belt clip

Fig. A

11. Charger
12. Charge indicator

Assembly

Warning! Before assembly, remove the battery from the tool.

Fitting and removing the battery (fig. B)

- ◆ To fit the battery (7), line it up with the receptacle on the tool. Slide the battery into the receptacle and push until the battery snaps into place.
- ◆ To remove the battery, push the release button (13) while at the same time pulling the battery out of the receptacle.

Fitting and removing a drill bit or screwdriver bit

This tool is fitted with a keyless chuck to allow for an easy exchange of bits.

- ◆ Lock the tool by setting the forward/reverse slider (2) to the centre position.
- ◆ Open the chuck by turning it (4) with one hand while holding the tool with the other.
- ◆ Insert the bit shaft into the chuck.
- ◆ Firmly tighten the chuck by turning it (4) with one hand while holding the tool with the other.

This tool is supplied with a double-ended screwdriver bit in the bit holder (6).

- ◆ To remove the screwdriver bit from the bit holder, lift the bit from the recess.
- ◆ To store the screwdriver bit, firmly push it into the holder.

Use

Warning! Let the tool work at its own pace. Do not overload.

Warning! Before drilling into walls, floors or ceilings, check for the location of wiring and pipes.

Charging the battery (fig. A)

The battery needs to be charged before first use and whenever it fails to produce sufficient power on jobs that were easily done before. The battery may become warm while charging; this is normal and does not indicate a problem.

Warning! Do not charge the battery at ambient temperatures below 10 °C or above 40 °C. Recommended charging temperature: approx. 24 °C.

Note: The charger will not charge a battery if the cell temperature is below approximately 0 °C or above 40 °C.

The battery should be left in the charger and the charger will begin to charge automatically when the cell temperature warms up or cools down.

- ◆ To charge the battery (7), insert it into the charger (11).
The battery will only fit into the charger in one way. Do not force. Be sure that the battery is fully seated in the charger.
- ◆ Plug in the charger and switch on at the mains.

The charging indicator (12) will flash green (slowly).

The charge is complete when the charging indicator (12) lights green continuously. The charger and the battery can be left connected indefinitely with the LED illuminated. The LED will change to flashing green (charging) state as the charger occasionally tops up the battery charge. The charging indicator (9) will be lit as long as the battery is connected to the plugged-in charger.

- ◆ Charge discharged batteries within 1 week. Battery life will be greatly diminished if stored in a discharged state.

Leaving the battery in the charger

The charger and battery pack can be left connected with the LED glowing indefinitely. The charger will keep the battery pack fresh and fully charged.

Charger diagnostics

If the charger detects a weak or damaged battery, the charging indicator (12) will flash red at a fast rate. Proceed as follows:

- ◆ Re-insert the battery (7).
- ◆ If the charging indicators continues flashing red at a fast rate, use a different battery to determine if the charging process works properly.
- ◆ If the replaced battery charges correctly, the original battery is defective and should be returned to a service centre for recycling.
- ◆ If the new battery gives the same indication as the original battery, take the charger to be tested at an authorised services centre.

Note: It may take as long as 60 minutes to determine that the battery is defective. If the battery is too hot or too cold, the LED will alternately blink red, fast and slow, one flash at each speed and repeat.

Selecting the direction of rotation (fig. C)

For drilling and for tightening screws, use forward (clockwise) rotation. For loosening screws or removing a jammed drill bit, use reverse (counterclockwise) rotation.

- ◆ To select forward rotation, push the forward/reverse slider (2) to the left.
- ◆ To select reverse rotation, push the forward/reverse slider to the right.
- ◆ To lock the tool, set the forward/reverse slider into the centre position.

Selecting the operating mode or torque (fig. D)

This tool is fitted with a collar to select the operating mode and to set the torque for tightening screws. Large screws and hard workpiece materials require a higher torque setting than small screws and soft workpiece materials. The collar has a wide range of settings to suit your application.

- ◆ For drilling in wood, metal and plastics, set the collar (3) to the drilling position by aligning the symbol  with the marking (14).
- ◆ For screwdriving, set the collar to the desired setting.
If you do not yet know the appropriate setting, proceed as follows:
 - Set the collar (3) to the lowest torque setting.
 - Tighten the first screw.
 - If the clutch ratchets before the desired result is achieved, increase the collar setting and continue tightening the screw. Repeat until you reach the correct setting. Use this setting for the remaining screws.

Speed selector (fig. E)

- ◆ For drilling in steel and for screwdriving applications, slide the speed selector (5) towards the rear of the tool (1st gear).

- ◆ For drilling in materials other than steel, slide the speed selector (5) towards the front of the tool (2nd gear).

Drilling/screwdriving

- ◆ Select forward or reverse rotation using the forward/reverse slider (2).
- ◆ To switch the tool on, press the switch (1). The tool speed depends on how far you press the switch.
- ◆ To switch the tool off, release the switch.

LED work light

The LED work light (8) is activated automatically when the trigger is depressed. The LED work light will illuminate when the trigger is partially depressed, before the unit begins running.

State of charge indicator

The tool is fitted with a state of charge indicator. This can be used to display the current level of charge in the battery during use.

- ◆ Press the state of charge indicator button (9).

Hints for optimum use

Drilling

- ◆ Always apply a light pressure in a straight line with the drill bit.
- ◆ Just before the drill tip breaks through the other side of the workpiece, decrease pressure on the tool.
- ◆ Use a block of wood to back up workpieces that may splinter.
- ◆ Use spade bits when drilling large diameter holes in wood.
- ◆ Use HSS drill bits when drilling in metal.
- ◆ Use masonry bits when drilling in soft masonry.
- ◆ Use a lubricant when drilling metals other than cast iron and brass.
- ◆ Make an indentation using a centre punch at the centre of the hole to be drilled in order to improve accuracy.

Screwdriving

- ◆ Always use the correct type and size of screwdriver bit.
- ◆ If screws are difficult to tighten, try applying a small amount of washing liquid or soap as a lubricant.
- ◆ Always hold the tool and screwdriver bit in a straight line with the screw.

Maintenance

Your Stanley FatMax tool has been designed to operate over a long period of time with a minimum of maintenance.

Continuous satisfactory operation depends upon proper tool care and regular cleaning.

Your charger does not require any maintenance apart from regular cleaning.

Warning! Before performing any maintenance on the tool, remove the battery from the tool. Unplug the charger before cleaning it.

- ◆ Regularly clean the ventilation slots in your tool and charger using a soft brush or dry cloth.
- ◆ Regularly clean the motor housing using a damp cloth.
- ◆ Do not use any abrasive or solvent-based cleaner.
- ◆ Regularly open the chuck and tap it to remove any dust from the interior.

Protecting the environment



Separate collection. This product must not be disposed of with normal household waste.

Should you find one day that your Stanley FatMax product needs replacement, or if it is of no further use to you, do not dispose of it with household waste. Make this product available for separate collection.



Separate collection of used products and packaging allows materials to be recycled and used again.

Re-use of recycled materials helps prevent environmental pollution and reduces the demand for raw materials.

Local regulations may provide for separate collection of electrical products from the household, at municipal waste sites or by the retailer when you purchase a new product.

Batteries



Stanley FatMax batteries can be recharged many times. At the end of their useful life, discard batteries with due care for our environment:

- ◆ Run the battery down completely, then remove it from the tool.
- ◆ NiCd, NiMH and Li-Ion batteries are recyclable. Take them to any authorised repair agent or a local recycling station.

Technical data

Australia & New Zealand

Stanley Black & Decker

82 Taryn Drive, Epping, VIC 3076 Australia

Tel.1800 338 002 (Aust) or Tel. 0800 339 258 (NZ)

FMC600 (H1)		
Voltage	V_{oc}	18
No-load speed	Min ¹	0-400/0-1600
Max. torque	Nm	49.6
Chuck capacity	mm	13
Max Drilling capacity		
Steel/wood	mm	13/38

Charger		905998** typ. 1	906086** typ. 1
Input Voltage	V_{ac}	230	230
Output Voltage	V_{oc}	18	18
Current	A	1	2
Approx. charge time	min	90 - 240	45 - 120

Battery		FMC685L	FMC687L	FMC688L
Voltage	V_{oc}	18	18	18
Capacity	Ah	1.5	2.0	4.0
Type		Li-Ion	Li-Ion	Li-Ion

Level of sound pressure according to EN 60745:	
Sound pressure ($L_{p,m}$)	88 dB(A), uncertainty (K) 3 dB(A)
Sound power ($L_{w,m}$)	99 dB(A), uncertainty (K) 3 dB(A)

Vibration total values (triax vector sum) according to EN 60745:	
Drilling into metal ($a_{h,v}$)	2.7 m/s ² , uncertainty (K) 1.5 m/s ²
Screwdriving without impact ($a_{h,v}$)	< 2.5 m/s ² , uncertainty (K) 1.5 m/s ²