

1800KG TROLLEY JACK



Value you can trust



1800KG TROLLEY JACK

Owners/Instruction Manual

THIS TROLLEY JACK COMPLIES WITH TROLLEY JACK STANDARD AS/NZS 2615:2004 AS AMENDED BY CPN No.10 OF 2008 (THE MANDATORY TROLLEY JACK STANDARD)



Manufactured and packaged for SRGS PTY LTD ABN 23 113 230 050
751 Gympie Road, Lawnton, Queensland 4501, Australia

PLU 526334

WARRANTY

This product is guaranteed against defects for a period of 12 months from date of purchase. This warranty is provided by Super Cheap Auto Pty Ltd ACN 085 395 124 (Supercheap Auto) of 751 Gympie Rd Lawnton QLD 4501 Ph (07) 3482 7500. Supercheap Auto will offer a repair, replacement product or store credit if the product is assessed as being defective during the warranty period.

To claim under this warranty, take this product to the Front Service Desk of your nearest Supercheap Auto store. For store locations, visit www.supercheapauto.com.au (AUS) or www.supercheapauto.co.nz (NZ). You will need your receipt or proof of purchase. Additional information may be requested of you to process your claim. Should you not be able to provide proof of purchase with a receipt or a bank statement, identification showing your name, address and signature may be required to process your claim.

This product may need to be sent to the manufacturer to assess the defect before determining any claim. Faults or defects caused by product modification, misuse and abuse, normal wear and tear or failure to follow user instructions are not covered under this warranty.

Our goods come with guarantees that cannot be excluded under the Australian Consumer Law. You are entitled to a replacement or refund for a major failure and for compensation for any other reasonably foreseeable loss or damage. You are also entitled to have the goods repaired or replaced if the goods fail to be of acceptable quality and the failure does not amount to a major failure.

Any expenses incurred relating to the return of this product to store will normally have to be paid by you. For more information contact your nearest Supercheap Auto store.

The benefits to the consumer given by this warranty are in addition to other rights and remedies of the Australian Consumer Law in relation to the goods and services to which this warranty relates.

WARNING

- The hydraulic trolley jack should be used on a hard level surface and be free to roll during lifting and lowering.
- The unlifted wheels of the vehicle should be chocked.
- The load should be centrally located on the head cap.
- No person should remain in a vehicle that is being lifted.
- The hydraulic trolley jack should be used for lifting and lowering only; the raised vehicle should be supported on vehicle support stands.
- No person should get bodily under a vehicle that is supported by a hydraulic trolley jack.
- The vehicle manufacturer owner's manual should be consulted prior to the lifting of the vehicle.

ASSEMBLY INSTRUCTION

TO ASSEMBLE THE JACK FOR USE:

1. Screw together the 2 parts of the handle.
2. Insert the assembled handle into handle socket on the jack.

SPECIFICATIONS

Working Load Limit: 1800kg
Jack Dimensions: 535mm x 205mm x 145mm
Height Lowered: 136mm
Height Raised: 384mm
This hydraulic trolley jack is designed to be used with a 54mm diameter head cap, and a handle length of 645mm length.

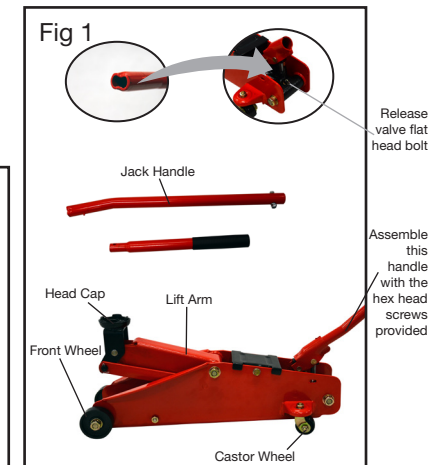

SAFETY INSTRUCTIONS & OPERATION

INSPECTION:

1. Before each use a visual inspection of the jack should be made. This should check for things such as cracks in the welds, leaking oil, any general damage, and loose or missing parts.
2. An annual inspection of the jack is recommended.
3. Do not use if any damage is evident.

CAUTION BEFORE USE:

Lubricate all pivoting and moving points - see LUBRICATION on Page 5. Occasionally during shipment and/or handling, air can become trapped in the hydraulic system.

This can interfere with the jacks lifting performance. To alleviate this problem:

1. Ensure the jack is in lowered position. Open the release valve by turning the jack handle anti-clockwise.
2. Rapidly pump the jack handle several times.
3. Open the air vent by removing the filler plug on the oil chamber.
4. Replace the filler plug. This process may need to be repeated several times to purge all air out of the hydraulic system.

TO RAISE THE JACK:

1. Close the release valve by turning clockwise with the jack handle until the release valve is closed. Do not over tighten.
2. Chock the wheels of the vehicle with wheel chocks. This will help ensure that the vehicle will remain stable during lifting.
3. Place the jack so the head cap on the lifting arm is directly under the object to be lifted. Please refer to the vehicle manufacturer owner's manual to locate approved lifting points on the vehicle.
4. Pump the jack handle until the head cap is almost in contact with the vehicle. Check that the head cap will be centrally located at the vehicle manufacturers recommended lifting point.
5. Continue to pump the jack handle to lift the vehicle to the desired height.
6. After lifting the vehicle to the desired height, support the load with approved vehicle support stands before working under the vehicle.

TO LOWER THE JACK:

1. With the jack supporting the weight of the vehicle, remove the vehicle support stands.
2. Very slowly turn the release valve anti-clockwise using the jack handle. This will open the release valve and when the release valve starts to open, the lifting arm will lower.
3. The speed which the jack will lower, will be dependent on how rapidly the valve is opened. The greater it is opened the faster the jack will lower.

CAUTION:

Ensure all hands, feet and all other items are well clear of the ground area when lowering the load.

MAINTENANCE

OIL TYPE:

IMPORTANT: When adding or replacing oil, always use a good grade of HYDRAULIC FLUID. (Recommended ISO VG32, SAE10 or equivalent) **Avoid** mixing types of fluid. **DO NOT** use Brake Fluid, Alcohol, Glycerine, Detergent, Motor Oil or Dirty Oil.

ADDING OIL & OIL LEVEL:

1. Set the jack in a horizontal level position and fully lower the head cap. Remove the rubber bung on the oil chamber (Fig. 2).
2. Fill using oil can with a fine spout. The recommended oil capacity is approximately 105ml. If low, add oil as required.
3. Replace the rubber bung on the oil chamber.

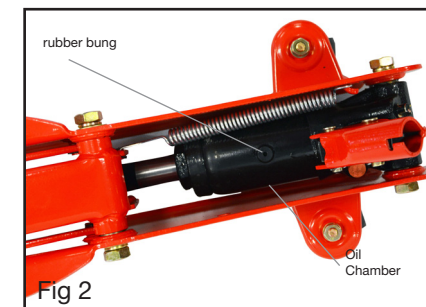

REPLACING OIL:

1. Remove the rubber bung on the oil chamber.
2. Turn the jack upside down and drain the old oil out through the hole of the oil chamber (Fig. 2).
3. Fill the jack with new oil through the hole of the oil chamber.
Do not allow any dirt or other foreign material to enter the hydraulic system when re-filling.

After Re-filling the jack oil, remove any air from the hydraulic system (please refer to caution on page 3 before use)

LUBRICATION:

Lubricate all pivoting and moving points with lubricating oil prior to initial use and after every 20 lifting/lowering cycles or 3 months (whichever occurs first)

RUST PREVENTION & STORAGE:

1. Check jack every few months for any signs of rust or corrosion. Clean as needed by wiping with an oily cloth.
2. When not in use, always store jack with wheels on horizontal surface and with lifting arm lowered all the way.

TROUBLE SHOOTING

POSSIBLE PROBLEMS						POSSIBLE CAUSES AND SOLUTIONS (Refer to operation and maintenance procedures for detailed information)
Jack will not lift load	Jack will lift load, but will not hold	Jack will not lower completely	Poor jack lifting. Pump feels spongy	Jack will not lift to full height	Handle raises by itself when jack is under load	
X						Ensure that the release valve has been turned clockwise to a point at which it is firm/tight.
X			X	X	X	Air is in hydraulic system. Release air from system.
X	X		X	X		Oil level is low in jack. Add oil as required.
		X				1. Oil reservoir is over-filled. Drain out some oil. 2. Lubrication of all pivoting and moving parts is necessary.

PARTS LIST

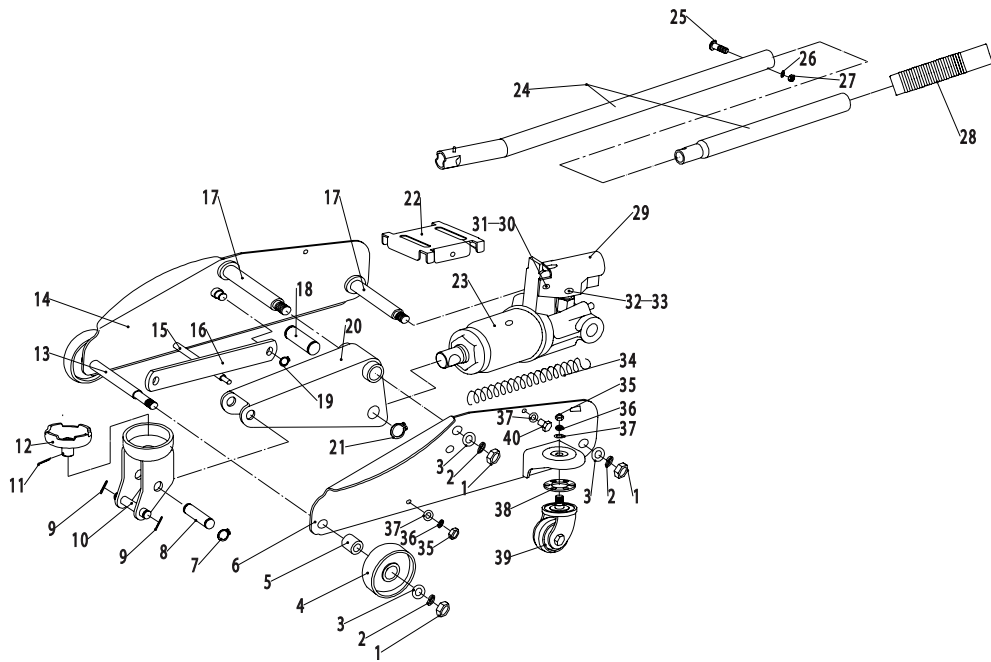

Ref. No.	Qty.	Description	Ref. No.	Qty.	Description
1	6	M12 Nut	22	2	Ø19 Retaining Ring
2	6	Ø12 Spring Washer	23	1	Cover Plate
3	6	Ø12 Flat Washer	24	1	Hydraulic Ram Assembly
4	2	Front Wheel	25	1	Handle
5	2	Shaft Sleeve	26	1	M6*30 Hex Head Screw
6	1	Left Main Frame	27	1	Ø6 Spring Washer
7	3	Ø13 Retaining Ring	28	1	M6 Lock Nut
8	1	Head Cap Shaft	29	1	The Handle Cover
9	2	#2.5*20 Cotter Pin	30	1	Handle Socket
10	1	Head Cap Seat	31	1	Pin For Handle Socket
11	1	#2.5*25 Cotter Pin	32	1	Insert Spring 2
12	1	Inner Head Cap	33	1	Pin For Pump Core
13	1	Front Wheel Shaft	34	1	Insert Spring 1
14	1	Right Main Frame	35	1	Tension Spring
15	1	Reforcing Spindle	36	4	Hexagonal Nut
16	2	Link Rod	37	4	Ø8 Spring Washer
17	2	Lift Arm Shaft	38	6	Ø8 Flat Washer
18	1	Ram Connecting Rod	39	2	Steel Plate
19	2	Ø10 Retaining Ring	40	2	Rear Castor Wheel
20	1	Lift Arm Assembly	41	2	M8*14 Bolt

Note: Some parts are listed and shown for illustration purpose only, and are not available individually as replacement parts.