



PR3205 FUEL CONTAINER HOLDER INSTRUCTIONS

FIRST TIME INSTALLATION

- Please read instructions carefully before installation.
- Check the contents of kit. Contact your Prorack dealer if any parts appear to be missing or damaged.
- Clean your roof racks and cargo tray prior to fitting the Prorack Fuel Container Holder.

IMPORTANT WARNING!

IT IS CRITICAL THAT ALL PRORACK RACKS AND ACCESSORIES BE PROPERLY AND SECURELY ATTACHED TO YOUR VEHICLE. IMPROPER ATTACHMENT COULD RESULT IN AN AUTOMOBILE ACCIDENT, AND COULD CAUSE SERIOUS BODILY INJURY OR DEATH TO YOU OR TO OTHERS. YOU ARE RESPONSIBLE FOR SECURING THE RACKS AND ACCESSORIES TO YOUR CAR, CHECKING THE ATTACHMENTS PRIOR TO USE, AND PERIODICALLY INSPECTING THE PRODUCTS FOR ADJUSTMENT, WEAR, AND DAMAGE. THEREFORE, YOU MUST READ AND UNDERSTAND ALL OF THE INSTRUCTIONS AND CAUTIONS SUPPLIED WITH YOUR PRORACK PRODUCT PRIOR TO INSTALLATION OR USE. IF YOU DO NOT UNDERSTAND ALL OF THE INSTRUCTIONS AND CAUTIONS, OR IF YOU HAVE NO MECHANICAL EXPERIENCE AND ARE NOT THOROUGHLY FAMILIAR WITH THE INSTALLATION PROCEDURES, YOU SHOULD HAVE THE PRODUCT INSTALLED BY A PROFESSIONAL INSTALLER SUCH AS A ROOF RACK SPECIALIST.

KIT CONTENTS

Item	Component	Qty
1	Fuel Container Holder	1
2	Ratchet & Short Webbing Strap	1
3	Long Webbing Strap	1
4	M6 Capscrew Button Head	4
5	M6 Washer	8
6	M6 Nylock Nut	4
7	M10 x 25mm Set Screw	2
8	M10 Spring Washer	2
9	M10 Washer	2
10	M10 Spring Nut	2
11	M10 x 20mm Set Screw	2
12	M10 T-Nut	2
13	M8 x 16mm Set Screw	2
14	M8 Spring Washer	2
15	M8 Washer	2
16	M8 T-Slot Nut	2
17	Holder Mounting Bracket	2
18	4mm Allen Key	1

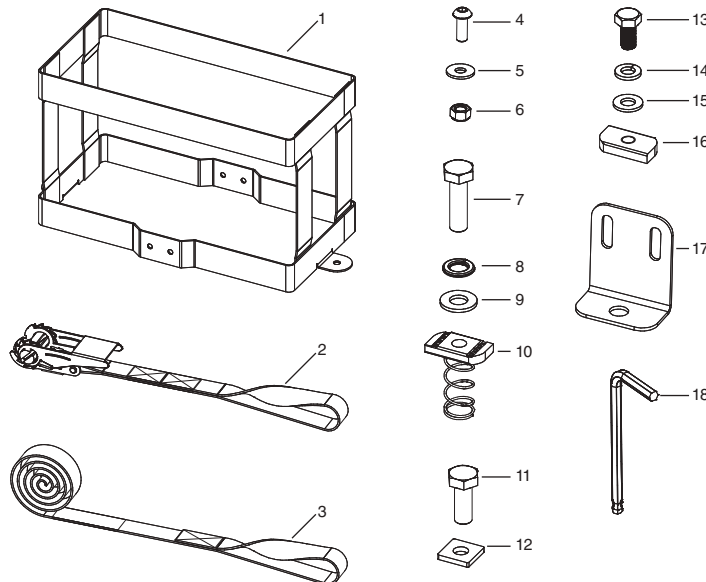

TOOLS REQUIRED

- Allen Key (provided)
- 13mm/16mm Spanner
- 16mm Socket + Socket Wrench (for dual side-by-side installation)

INSTALLING FUEL CONTAINER HOLDER ON TO A CARGO TRAY WITH T-SLOT CHANNELS ► GO TO STEP 7

INSTALLATION INTO CROSSBAR CHANNELS

- 1 Turn the fuel container holder upside down and fit both mounting brackets on to the long side of the holder.

Ensure brackets are fitted on the inside of the holder and that the screw heads face inwards. Tighten capscrews with Allen key to 4-5Nm.

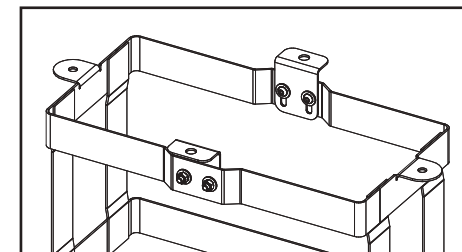
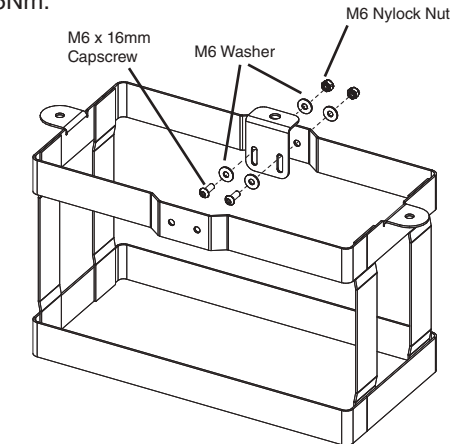

INSTALLATION FOR STANDARD CARGO TRAYS ON PRORACK HD, TRADESMAN AND OTHER HEAVY DUTY CROSSBARS

- 3** Position 2x M10 spring nuts into the crossbar channel either side of tray slat where holder will be positioned. Push spring nuts down into crossbar channel and twist to lock into place.

Use the assembled holder from step 1 to ensure spring nuts align with holes in brackets.

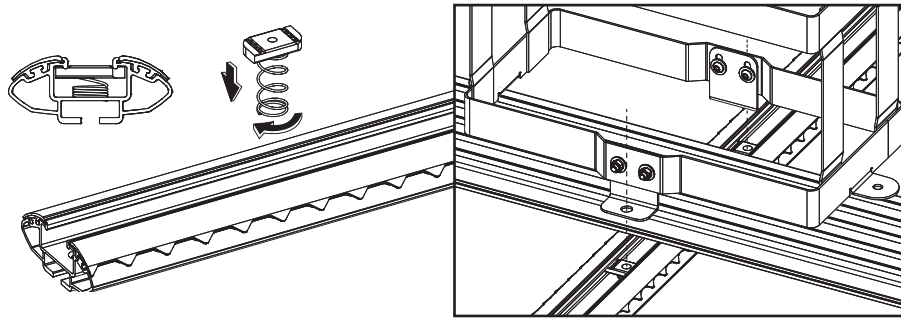

- 4** Secure each mounting bracket on to the spring nuts in the crossbar using 2x M10 x 25mm set screws, 2x M10 spring washers and 2x M10 washers. Use a 16mm spanner to tighten screws to 4-5Nm.

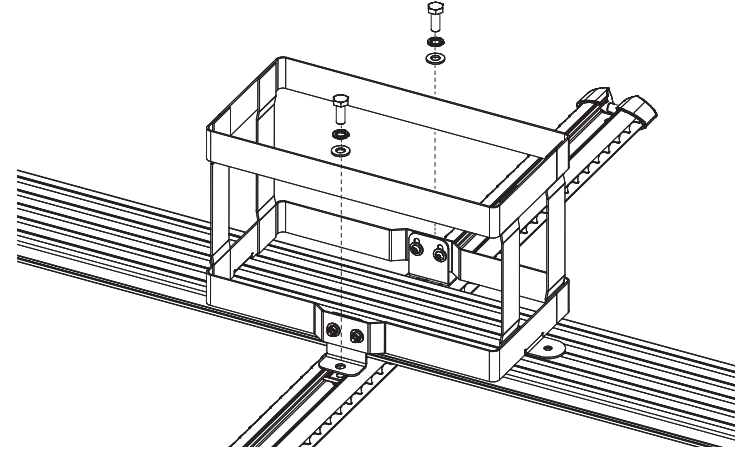

INSTALLATION FOR STANDARD CARGO TRAYS ON PRORACK S-WING AND INTERNATIONAL T-SLOT CROSSBARS

- 5** Push rubber infill down and slide 2x M10 T-nuts into the crossbar channel either side of tray slat where holder will be positioned.

Use the assembled holder from step 1 to ensure T-nuts align with holes in brackets.

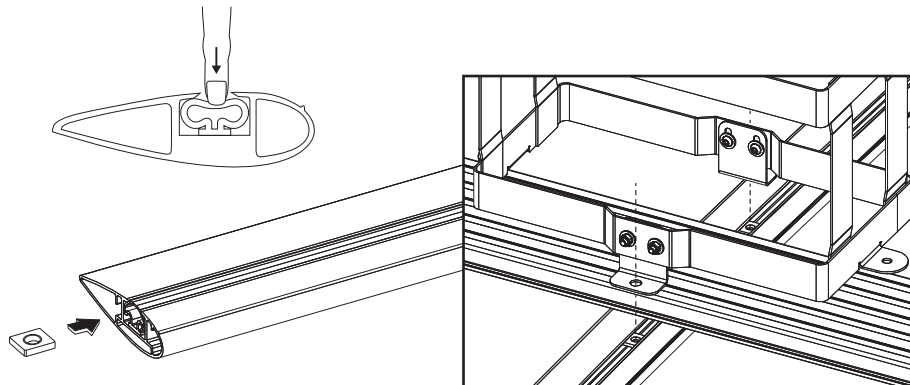

- 6** Secure each mounting bracket on to the T-nuts in the crossbar using 2x M10 x 20mm set screws, 2x M10 spring washers and 2x M10 washers. Use a 16mm spanner to tighten screws to 4-5Nm.

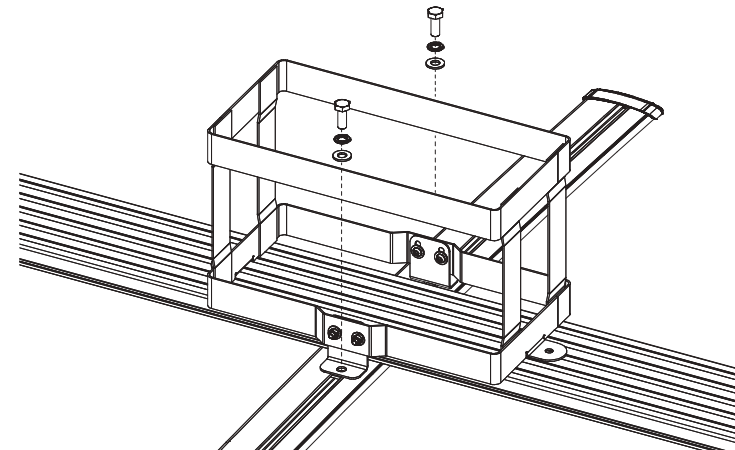

INSTALLATION FOR CARGO TRAYS WITH T-SLOT CHANNELS

- 7** Slide 2x M8 nuts into the T-slot of the tray

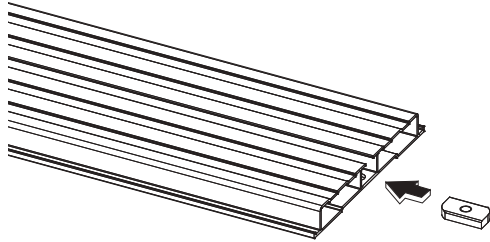

- 8** Position holder centrally over a crossbar in the preferred position. Secure the fuel container holder on to the M8 nuts in the T-slot using 2x M8 x 16mm set screws, 2x M8 spring washers and 2x M8 washers. Use a 13mm spanner to tighten screws to 4-5Nm.

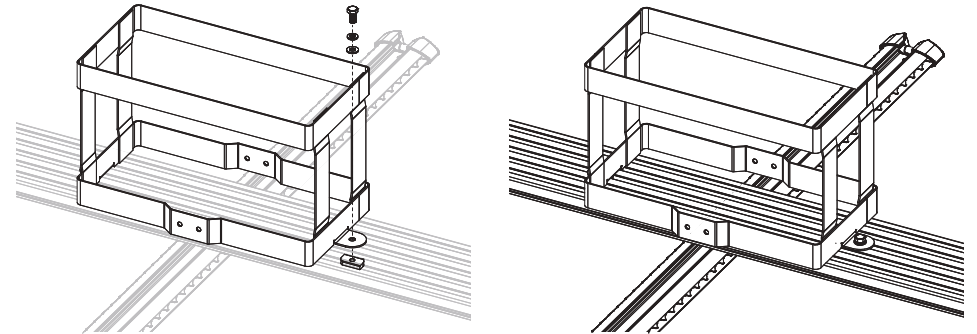

SECURING THE FUEL CONTAINER HOLDER

- 9** Place the fuel container vertically into the holder ensuring the filler cap is facing upwards as shown.

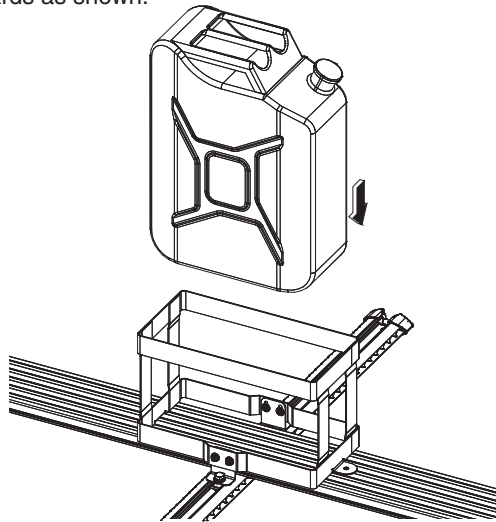

- 10** Loop the ratchet through the handle in the short strap around the crossbar on one side of the holder and loop the long strap through its handle around the crossbar on the other side of the holder.

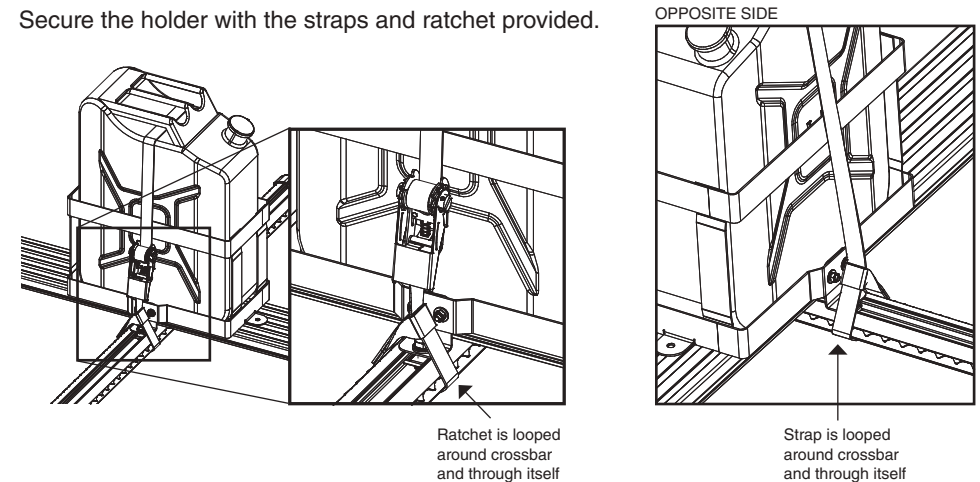

INSTALLATION OF DUAL FUEL CONTAINER HOLDERS

For this configuration, one mounting bracket will be required to sit on the other as shown. Adjust position of the mounting brackets to ensure both holders sit flat on the cargo tray.

Using an M10 x 25mm set screw, an M10 spring washer and an M10 washer, assemble the two holders on to the spring nut or T-nut in the crossbar channel. Use a 16mm socket & socket wrench to tighten the set screw to 4-5Nm.

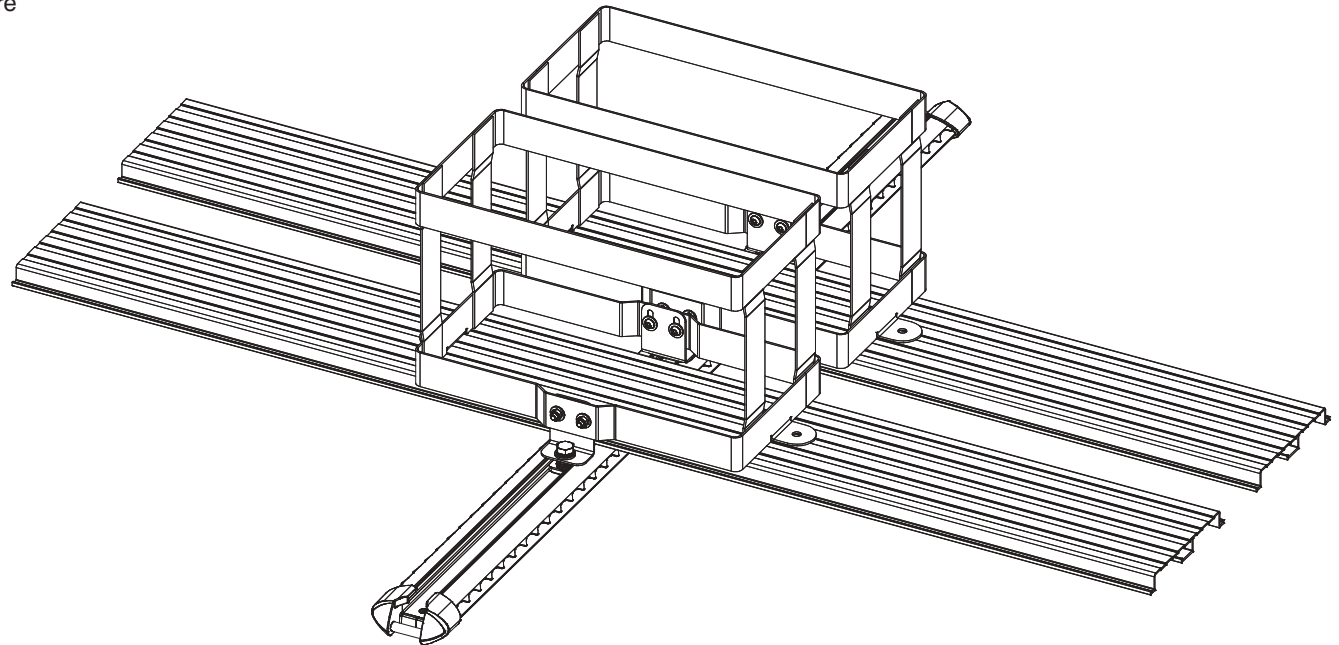
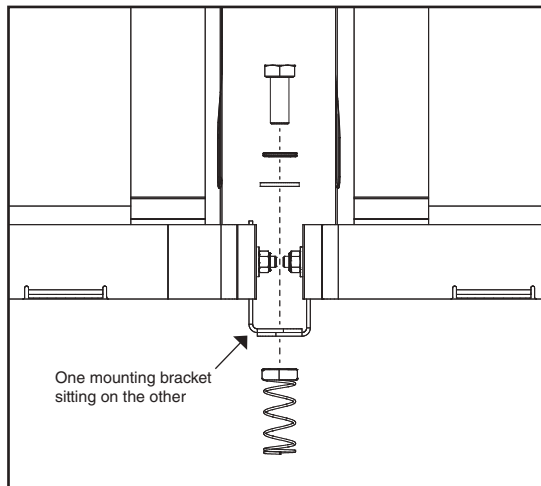

MAINTENANCE

- Check accessory is securely attached whenever you refit it to the vehicle. If the unit feels loose, refer to the fitting instructions and readjust.
- Regularly check all fasteners. This includes all attached accessories and roof racks.
- If straps become contaminated with oil, fuel or acid remove with hot soapy water.
- If the ratchet mechanism becomes stiff in use, a small amount of lubrication applied to the moving parts will ease operation.

CAUTION

- Ensure that all loads are distributed evenly across the roof racks and are fastened securely.
- A loaded roof rack system can alter the performance of your vehicle. Be especially aware of the effects of side winds, changing of direction, and braking performance. Avoid rapid acceleration and deceleration. Drive Carefully.
- Make sure all loads are securely fastened with non-elastic straps. Check regularly during longer journeys.
- Never drive into a car wash with the roof rack system fitted.
- Do not exceed the vehicle manufacturer's roof load rating. Total load equals weight of roof racks + accessories + cargo/equipment.
- Ratcheting strap must not be used for lifting. Protect from abrasion and friction. Do not tie knots in the straps. Do not use a damaged strap.
- 150kg lashing capacity on the polypropylene webbing.

WARRANTY & DISCLAIMER

Yakima Australia Pty Ltd ABN 58 154 440 221

17 Hinkler Court, Brendale QLD 4500

Tel: 0800 4776 722 (NZ) or 1800 143 548 (AU)

Email: warranty@yakima.co.nz or warranty@yakima.com.au

1. Where the product is supplied to the customer for other than business purposes within the meaning of section 43 of the New Zealand Consumer Guarantees Act 1993, the provisions of that Act shall apply. It is important that anyone who fits or uses this product does so in accordance with the manufacturer's instructions.
2. Where the product is supplied to the customer for business purposes within the meaning of section 43 of the New Zealand Consumer Guarantees Act 1993, the provisions of that Act and all other representations or terms (including any conditions or warranty expressed or implied by law, statute or otherwise) not expressly included in this leaflet are hereby expressly excluded shall have no effect and the clauses (a) and (b) shall apply.
3. Subject to the **Additional Information (Australia)**, where the product is supplied and purchased in Australia, the following shall apply:
 - (a). THE SUPPLIER WARRANTS the product to be free from defects in materials and/or workmanship for a period of three (3) years from the date of original purchase (the warranty period). Proof of purchase is required. Subject to the limitations and exclusions set out below, the Supplier hereby agrees to remedy any defects in materials or workmanship becoming apparent during the warranty period, by replacing or repairing any defective product or component (at its option) free of charge to the purchaser in respect of replacement parts or labour. Any defective product or component must be notified and where practicable, returned at the purchaser's expense to the Supplier immediately upon discovery of the alleged defect and no attempt made on the part of the purchaser to repair it.
 - (b). EXCEPTIONS, EXCLUSIONS AND LIMITATIONS TO WARRANTY. The product and/or its components must be fitted/ assembled and loaded in accordance with the Supplier's written instructions and any requirements set out in the car's owner manual. This warranty does not cover defects, loss or damage resulting from circumstances beyond the Supplier's control including, but not limited to misuse, overloading, or failure to assemble and/or fit the product or component in accordance with the Supplier's written instructions. Nor does the warranty cover defects, loss or damage resulting from accidents, unlawful use of the vehicle or defects/inconsistencies in the vehicle on which the product or component is fitted. Liability for direct, indirect, special, punitive, incidental, exemplary, contractual or consequential damage or loss arising from defects, faulty materials or design omissions or negligence or workmanship in the product or its components is hereby expressly excluded subject to the following. Certain Commonwealth legislation, including the Competition and Consumer Act 2010 (Cth), and other State and Territorial legislation confers upon purchasers rights which cannot be excluded from or be restricted or modified by contract. Any conditions, guarantees and/or warranties implied by law and incapable of exclusion are deemed to be expressly incorporated herein. Nothing herein contained is intended nor shall be permitted to be inconsistent with any such conditions, guarantees and/or warranties. To the extent permitted by legislation all conditions, guarantees and/or warranties such as implied warranties which are capable of exclusion are hereby expressly excluded and negated.

ADDITIONAL INFORMATION (AUSTRALIA)

This information should be read in conjunction with clauses (a) and (b).

IMPORTANT LEGAL NOTICE

Our goods come with guarantees that cannot be excluded under the Australian Consumer Law. You are entitled to a replacement or refund for a major failure and for compensation for any other reasonably foreseeable loss or damage. You are also entitled to have the goods repaired or replaced if the goods fail to be of acceptable quality and the failure does not amount to a major failure.

This warranty does not change or take away your rights under the Australian Consumer Law. Your right to claim under this policy for the benefits covered is in addition to other rights and remedies you have under the law in relation to the product.

Where you become aware of defects in materials or of workmanship, and wish to make a claim under this warranty you must do the following for the warranty to be honoured by your Prorack dealer or Yakima Australia Pty Ltd ABN 58 154 440 221 (Yakima):

1. Make a claim as soon as practicable by contacting the Prorack dealer from whom you purchased the product, who will give you instructions on how to proceed.
2. If you are unable to contact the Prorack dealer, or the dealer is not able to remedy the defect, you should contact Yakima as soon as practicable at:

Call: 0800 4776 722 (NZ) or 1800 143 548 (AU)

Email: warranty@yakima.co.nz or warranty@yakima.com.au

Alternately, you can write to Yakima at 17 Hinkler Court, Brendale QLD Australia 4500 in order to make a claim under your warranty.

3. Upon contacting Yakima directly, you should explain as fully as possible the defect. A Yakima representative will provide you with appropriate instructions for returning the product together with a copy of the original purchase invoice or receipt to Yakima.
4. The costs and expenses associated with making a claim under your warranty including the costs of complying with those instructions and of returning the product to Yakima or the Prorack dealer will be borne by you.

Following receipt of the product and purchase invoice or receipt, Yakima or the Prorack dealer must inspect the product to determine whether the claim falls within the warranty. If:

- 4.1 the claim falls within the warranty, Yakima will remedy any defects in materials or workmanship becoming apparent during the warranty period, by replacing or repairing any defective product or component (at its option) free of charge to the purchaser in respect of replacement parts or labour.
- 4.2 the claim does not fall within the warranty, Yakima will return the product to you at your expense.