

# STANLEY

®

**MODEL NO. AC6168**

2.5HP 40L Direct Drive Compressor



For service, spare parts or product information,  
please contact Smart Marketing Group Pty. Ltd.

**AUST. 1300 660 457    N.Z. 0800 474 876**

## SUGGESTED APPLICATIONS

You may use most light duty air tools with this compressor. Some examples of light duty tools are:

- Tyre Inflator
- Blow Gun
- Engine Cleaning Gun
- C Bradder
- T-Nailer
- Low Pressure Spray Gun
- Gravity Feed Spray Gun
- Air Hammer
- Sandblaster

This light duty air compressor is NOT recommended for use with a finishing spray gun or high pressure spray gun.

## CONTENTS

Section	Page
Contents	2
Suggested Applications	2
Introduction	3
Guarantee	3 – 4
General Safety Instructions	5 – 7
Electrical Information	8
Specific Safety Instructions	8 – 9
Components and Controls	9
Operating Instructions	10 – 15
Maintenance	15
Trouble Shooting	15
Parts Diagram	16
Technical Information	17
Contact Information	17

## INTRODUCTION

Dear Customer,

Thank you for purchasing this compressor which has passed through our extensive quality assurance processes. Every care has been taken to ensure that it reaches you in perfect condition. However, in the unlikely event that you should experience a problem, or if you require any assistance please do not hesitate to contact us;



**If you have a problem, call customer service do not return this compressor to the place of purchase.**

## CUSTOMER SERVICE

**Australia: 1300 660 457**

**New Zealand: 0800 474 876**

**Operating times: Monday – Friday 8.30am - 5.00 pm**

Australian Eastern Standard Time (AEST)

## EXPRESS WARRANTY STATEMENT - COMPRESSOR GROUP

You are not required to do anything to register your compressor purchase. Please attach the purchase receipt to this manual and ensure both are kept safe. We hope you enjoy your new compressor, and if you have any problems call customer service on the above phone numbers. Do not return to place of purchase.

Smart Marketing Group Pty Ltd (SMG) warrants that this compressor will be free from manufacturing faults or defects for 2 years from the date of purchase, providing original purchase receipt is kept and shown when needed and is subject to the terms and conditions below.

If a warranty fault appears within the warranty period, SMG reserves the right to replace or repair the product. In the event that SMG chooses to replace the product, this original warranty will expire at the original date. If the product includes various accessories or components, only the defective accessory or component will be replaced or repaired.

SMG reserves the right to replace defective parts of the product with parts and components of similar quality, grade and composition where an identical part or component is not available.

Products presented for repair may be replaced by refurbished products of the same type rather than being repaired. Refurbished parts may be used to repair the products.

### What is covered.

- Manufacturing fault or defect.

### How to claim under this warranty.

- Call customer service, phone number at the top.
- Ensure you have the following: Original purchase receipt, Model of compressor, Serial number of compressor.
- Discuss the issue.
- Customer service will advise which authorised service agent to take the compressor to provided the issue is a warranty one.
- Take compressor to authorised service agent for repair.

### What is not covered.

- Commercial use of compressor.
- Use of compressor in a commercial premises.
- Damage caused by incorrect fuel or incorrectly mixed 2 stroke fuel.
- Damage or deterioration due to transport.
- Damage caused by negligence, misuse, abuse or accident or incorrect voltage and wattage.
- Any corrosion or rusting.
- Damage caused by incorrect set up and start up.
- Replacement parts due to general wear and tear.
- Compressors with serial number defacement, modification or removal.
- Compressors which have been serviced by other than an authorised SMG service agent.
- Compressors with no original purchase receipt.
- Compressors which have been on sold, not original purchaser.
- Damage due non-servicing of compressor as is required by this manual.
- Blockages / damage caused by dust, dirt, spiders webs or insects.
- Damage caused by the incorrect fitting of accessories.
- Damage caused by overloading, overworking the compressor.
- Damage to attached equipment or third party accessories.
- Damage caused by attached equipment or third party accessories.

## CONTACT DETAILS

Smart Marketing Group Pty Ltd  
33-35 Lionel Road, Mt. Waverley  
Victoria 3149, Australia.  
Tel (+613) 9543 7266  
Fax (+613) 9543 9839  
sales@smga.com.au

## COMPLETE WARRANTY STATEMENT – COMPRESSOR GROUP

As soon as you have purchased the compressor, we recommend that you check to make sure it is intact and that you read the operating instructions carefully before using it. The purchase receipt for this product is to be retained and must be presented if making a claim under the terms of the Smart Marketing Group (SMG) warranty. Bank account statements are not acceptable for proof of purchase.

This warranty does not cover compressors intended for hire or use in commercial applications or in commercial premises. The warranty will under no circumstances extend to reimbursement or payment of damages, whether direct, indirect or consequential. The warranty is void if there is evidence the compressors has been modified or tampered with in any way or used with unauthorised accessories without our consent.

SMG declines any responsibility or liability whatsoever arising from misuse or abuse, negligent handling of the compressors or if the product has not been installed or failure to comply with the relevant safety, operating, setting and maintenance instructions (see further in this manual).

The warranty does not extend to installation or disconnection costs.

Any item sent freight forward/collect for repair will be refused. Warranty repairs are free of charge, provided the appliance is delivered to our service department or authorised service agent. The compressor will need to be returned, adequately protected in a box. SMG will not be responsible for any in-transit loss or damage. Assistance under the warranty will only be made available if the request is made to our customer service team on the contact numbers listed below and proof of purchase is provided.

This is a repair only warranty you will need to take the compressor to the authorised service agent after contacting our customer service centre.

If the product includes various accessories or components, only the defective accessory or component will be replaced or repaired.

SMG reserves the right to replace defective parts of the product with parts and components of similar quality, grade and composition where an identical part or component is not available.

Products presented for repair may be replaced by refurbished products of the same type rather than being repaired. Refurbished parts may be used to repair the products.

Damage caused by third party accessories is not covered under this warranty.

Damage caused to attached equipment or third party accessories will not be covered under this warranty.

Rust and corrosion are not covered under this warranty.

If a warranty fault is found the freight cost will be credited to the owner. If no fault is found the product will be returned and any costs associated with the service will be charged to the owner.

Blockages caused by spider webs, insects, dirt, accumulated dust, incorrect fuel or incorrectly mixed 2-stroke fuel are not covered by warranty. SMG reserves the right to replace or repair the appliance within the warranty period. Parts found to be defective due to a manufacturing default will be replaced free of charge.

In the event of SMG choosing to replace the appliance, the warranty will expire at the original date of purchase. If no warranty fault is found the owner will be advised and the product will be returned and any costs associated with the service will be charged to the owner.

Our goods come with guarantees that cannot be excluded under the Australian Consumer Law. You are entitled to a replacement or refund for a major failure and for compensation for any other reasonably foreseeable loss or damage. You are also entitled to have the goods repaired or replaced if the goods fail to be of acceptable quality and the failure does not amount to a major failure. The benefits of this warranty are in addition to any rights and remedies imposed by Australian State and Federal legislation that cannot be excluded.

In New Zealand, this SMG warranty is in addition to the conditions and guarantees which are mandatory as implied by the New Zealand Consumer Guarantee Act 1993. For service, spare parts or product information please contact customer service:

Australia: 1300 660 457

New Zealand: 0800 474 876

### CONTACT DETAILS

Smart Marketing Group Pty Ltd  
33-35 Lionel Road, Mt. Waverley  
Victoria 3149, Australia.  
Tel (+613) 9543 7266  
Fax (+613) 9543 9839  
sales@smga.com.au

## **LUBRICATION OF COMPRESSOR**

Before attempting to operate this air compressor the transport plug must be removed, thrown out and replaced with the oil breather. Check the oil level to ensure the level is to the top of the red dot on the sight glass; refer to page 10 for complete details and diagram. Failure to do these may result in damage to the air compressor and / or injury to the user.

PLEASE follow the instructions noted on page 10 on changing the transport plug to the oil breather.

## **ASSEMBLY**

This compressor **MUST** be fully assembled by you prior to use. Failure to do so will result in the warranty being VOID. Failure to fully assemble this compressor may also result in personal injury.

## **SAFETY**

Before attempting to operate this air compressor the following basic safety precautions should be taken to reduce the risk of fire, electric shock and personal injury. It is important to read the instruction manual and to understand applications, limitations and potential hazards associated with the air compressor. This air compressor is not intended for use by persons (including children) with reduced physical, sensory or mental capabilities, or lack of experience and knowledge, unless they have been given supervision or instruction concerning the use of the appliance by a person responsible for their safety.

## **BEWARE OF CHILDREN AND PETS**

Children and pets should be kept out of the work area. Children should not be allowed to touch or operate the air compressor, tools or extension cords. This air compressor is not designed for use by young children or infirm persons without supervision. The air compressor and tools should be kept out of reach of children, preferably stored or locked in a secure cabinet or room when not in use.

## **WORK AREA**

Work areas and benches should be kept tidy. Cluttered benches and work areas can cause accidents. Floors should be kept clean and free from rubbish. Special care should be taken when the floor is slippery due to sawdust or wax. Always leave sufficient distance, at least 5 metres between the air compressor and the work area, especially when using tools designed for sanding or spraying liquids.

## **WORK ENVIRONMENT**

Do not expose your air compressor to rain or use in damp or wet conditions. Keep the work area well lit. Always ensure your compressor is level and stable. Using your compressor on unlevel or unstable ground may cause a lack of lubrication and the pump to seize, this damage will not be covered under warranty.

## **GUARD AGAINST ELECTRIC SHOCK**

Avoid body contact with earthed or grounded surfaces (e.g. pipes and refrigerators).

## **DO NOT FORCE AIR COMPRESSORS**

The air compressor will do a better, safer job and give you much better service if it's used at the duty cycle for which it was designed. The duty cycle will only take effect after the initial (1st ) tank fill for the day. This air compressors duty cycle is 75%. Duty cycle is the proportion of time during which the air compressor is operating compared with not operating. For example a 75% duty cycle could mean after 45 seconds of operation, motor pumping, the air compressor must be left for 15 seconds resting, motor not pumping. When the motor is pumping the attached air tool can not be used. Only use the attached air tool while the compressor is not pumping. Stop using the attached tool as soon as the air compressor starts pumping.

## **USE THE RIGHT TOOL**

Select the right tool for the job. Do not use a tool for a job for which it was not designed. Do not force a small air compressor to do the job of a heavy-duty air compressor. Do not use the air compressor for purposes not intended.

## **DO NOT ABUSE THE POWER CORD**

Never yank or pull on the power cord to disconnect it from the mains supply socket. Never carry or pull your air compressor by its power cord. Keep the power cord away from heat, oil, solvents and sharp edges. Regularly check the plug and cord and if damaged have it replaced by an authorised service facility.

## **EXTENSION CORDS AND REELS**

This air compressor **MUST** be plugged directly into a 240V AC wall socket.

This air compressor is **NOT** designed to be run off an extension cord/lead. If you need extra distance do **NOT** use an extension cord, **USE A LONGER AIR HOSE**.

The use of extension cords may cause power voltage loss and will result in damage to the motor. This will **NOT** be covered under warranty.

## **SECURE THE WORK PIECE**

Whenever possible secure the work piece using clamps or a vice. It is safer than using your hands or feet and leaves both hands free to control the tool.

## **HOT COMPONENTS**

Beware many of the components will get hot during use. Never touch any of the metal pipes, pump or motor as these may burn.

## **MAINTAIN YOUR AIR COMPRESSOR WITH CARE**

Follow the instructions for lubricating and changing accessories. Check the air compressor power cord periodically and if damaged have it replaced by an authorised service facility. Keep handles clean, dry and free from oil and grease. Ensure that ventilation slots are kept clean and free from dust at all times. Blocked ventilation slots or air filter can cause overheating and damage to the motor and this will not be covered under warranty.

## **DISCONNECT AIR COMPRESSOR**

Ensure that the air compressor is disconnected from the mains supply when not in use, before servicing, lubricating, making adjustments or when changing any accessories.

## **REMOVE ADJUSTING KEYS AND WRENCHES**

Form the habit of always checking to see that any adjusting keys or wrenches have been removed from the air compressor or attached air tools before operating.

## **AVOID UNINTENTIONAL STARTING**

Ensure that the switch is in the 'OFF' position before plugging the air compressor into the mains supply.

## **PROTECT FURNISHINGS**

If using the air compressor inside your house, protect furnishings and floors with a suitable dust sheet.

## **FIRE PRECAUTIONS**

When using the air compressor inside your house or workshop general fire precautions should be observed. As a precaution it is recommended that an expert is consulted on obtaining and using a suitable fire extinguisher.

## **CLEANING YOUR AIR COMPRESSOR**

Always disconnect your air compressor from the mains power supply before you commence cleaning. Always ensure that your air compressor has cooled, about one (1) hour, before cleaning and storing. When cleaning your air compressor use only a damp soft cloth. **NEVER** use liquid or solvents of any type.

## CHECK DAMAGED PARTS

Before using the air compressor it should be carefully checked to determine that it will operate properly and perform its intended function.

Check for the correct alignment of moving parts ensuring that they do not bind. Check for broken or missing parts and have them replaced or repaired at an authorised service facility. Check any other condition that may affect the operation of the air compressor. A guard or any other part of the air compressor that is damaged should be properly repaired or replaced by an authorised service facility unless otherwise indicated in this instruction manual.

Any switch that does not operate correctly must be replaced by an authorised service facility.

DO NOT use the air compressor if the 'ON / OFF' button does not turn the air compressor 'ON' and 'OFF'.

## PERSONAL SAFETY

### Clothing

Do not wear loose clothing, jewelry or anything that could get caught in moving machinery.

### Hair

Long hair should be tied back or contained in a protective covering.

### Eye Protection

The use of safety goggles is highly recommended (normal glasses are not sufficient for eye protection) when using an air compressor. Prescription glasses do not have safety lenses.

### Footwear

Where there is the risk of heavy objects or if there is a risk of slipping on wet or slippery floors, suitable non-slip safety footwear should be worn. Protect your feet from dropping accidents.

### Ear Protection

The use of ear protection is highly recommended when using air compressors. The continual noise may damage your ears.

### Respiratory Protection

When operating any machinery that creates dust or when spray painting, an approved dust / filter mask must be worn. When machining concrete, man made fibres, especially MDF (Medium Density Fibre board), the resin used in these materials can be hazardous to your health. Use an approved face mask with replaceable filter.

### Do Not Over Reach

Do not over reach. Keep a proper footing and maintain your balance at all times. Avoid using abnormal stances and awkward body positions.

### Stay Alert

Watch what you are doing, use common sense, and never operate an air compressor when you are tired, drinking alcohol, taking drugs or if taking medication that causes drowsiness.



## WARNING

Do not attempt to modify the air compressor in any way; this will VOID your warranty.

The use of any attachment or accessory other than those recommended in this instruction manual could result in damage to the air compressor and could cause injuries to the operator.

This electric air compressor complies with Australian / New Zealand and International standards and safety requirements. Repairs should only be carried out by qualified persons using original spare parts. Failure to do so may result in considerable danger to the operator.

## ELECTRICAL DATA



### IMPORTANT

This air compressor is fitted with a sealed electrical connection plug that is compatible with the mains power supply for Australia / New Zealand and meets the requirements of Australian Standards. This air compressor must be connected to a supply voltage that is equal to that stated on the rating label. If the mains power connection plug or power cord becomes damaged it must be replaced with a complete assembly that is identical to the original, and this must be replaced by an authorised service centre. Always follow the Australian / New Zealand requirements for connection to the mains supply. If in doubt always consult a qualified electrician.

## SPECIFIC SAFETY INSTRUCTIONS

**Warning!** Do not use the air compressor in areas where there is a risk of explosion or fire from combustible materials. The sparks generated from certain tools attached to air compressor can ignite combustible materials as well as flammable liquids, paint, varnish, petrol, flammable gases and dust of an explosive nature. As a precaution it is recommended that you consult an expert on a suitable fire extinguisher and its use.

- **Initially remove the transport plug and replace with the oil breather BEFORE using the first time, see page 10.**
- **Do not attempt to modify the air compressor, guards or the supplied accessories in any way.**
- **Domestic air compressors are designed for intermittent operation. Ideally a 75% duty cycle. (Meaning. 45 seconds ON motor pumping and 15 seconds OFF, motor not pumping). When the motor is pumping the attached air tool can not be used. Only use the attached air tool while the compressor is not pumping.**
- **Stop using the attached tool as soon as the air compressor starts pumping.**
- **Always check the oil level before use. The oil level should be above the red dot on the sight glass.**
- **Fully assemble compressor before use.**
- **Always ensure your compressor is level and stable. Using your compressor on unlevel or unstable ground may cause a lack of lubrication and the pump to seize, this damage will not be covered under warranty.**
- **Never run this compressor without the wheels and/or rubber stopper (s) being correctly fitted.**
- **Never use an extension cord with this compressor always use a longer air hose.**
- **Never connect to a generator which does not produce sufficient power, at least 3500W and has pure sine wave power output.**
- **This air compressor has a maximum operating pressure of 10BAR (145PSI). Always regulate the outlet pressure to match your air tools operating pressure noted in your air tools instructions**
- Domestic air compressors are not designed for industrial / commercial applications.
- Domestic air compressors are not designed for continuous running.
- Avoid touching the pump area as it can become very hot and may burn.
- Ensure that the air compressor is disconnected from the mains supply when not in use, before servicing, lubricating, making changes and when changing attachments such as air hoses / tools.
- Always use the correct type of tool for the operation to be carried out.
- Never use the air compressor if any part of the unit is damaged. Always have the air compressor serviced by an authorised service agent.
- Always wear safety eye, ear and respiratory protection when operating the air compressor.
- Allow the tank to completely fill before using the air compressor.
- If the air compressor makes an unfamiliar sound or vibrates excessively, switch the air compressor 'OFF' immediately and disconnect from the mains power supply. Investigate the possible cause or consult your authorised service facility.
- Always move the air compressor using the handle and wheels.
- Always use the air compressor on stable ground.
- This air compressor is designed to compress normal air. Never use to compress any other type (s) of gases.
- Never direct the jet of air or other liquids / gases towards your body, other persons or animals.
- Never direct the jet of air or other liquids / gases towards this air compressor.
- This air compressor is not suitable for pharmaceutical, food or sanitary purposes.
- This air compressor is not to be used to fill scuba or oxygen air bottles or tanks.
- Always follow the instructions relating to the tools attached to this air compressor.



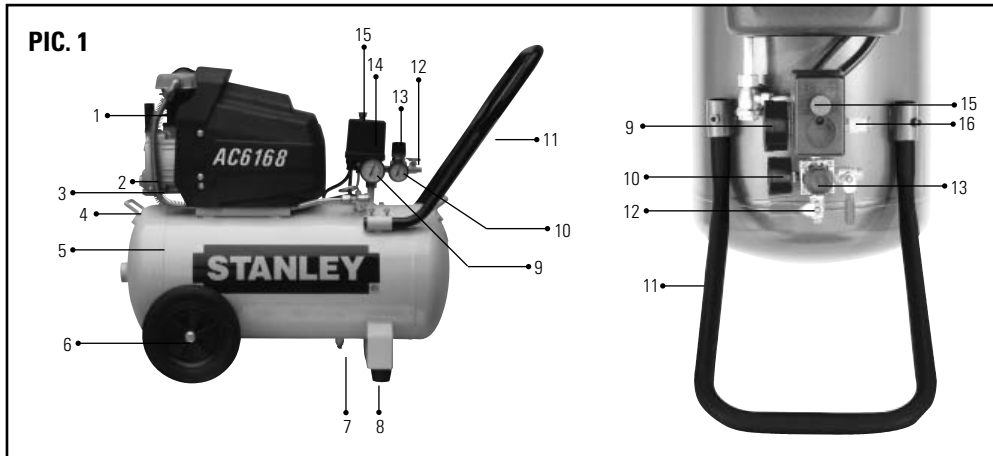

## COMPONENTS AND CONTROLS

**Pic. 1**

1. Oil fill and breather
2. Oil sight glass
3. Oil drain bolt
4. Rear handle
5. Tank
6. Wheels
7. Tank drain tap
8. Twin rubber stoppers
9. Tank pressure gauge - large
10. Outlet pressure gauge - small
11. Front handle (Large and small)
12. Air tap – Air outlet
13. Outlet pressure regulator
14. Pressure switch
15. On / Off button – red colour
16. Safety Valve
17. Air filter – metal (Not shown)
18. Transport Plug (Not shown)

## OPERATING INSTRUCTIONS

### Unpacking

Carefully unpack your air compressor. This air compressor is bulky and heavy, two (2) person lift required. Dispose of all packing material in an environmentally responsible manner.

### Assembly

Your air compressor requires minor assembly before initial operation. Check that you have all required components required for assembly and initial use.

Your compressor is filled with oil do not tip to assemble.

### Oil Breather:

#### To fit the oil breather:

1. Remove the transport plug and throw away, see Pic. 2.
2. Screw in the oil breather, see Pic. 2.

### Lubrication:

**Warning:** Your air compressor IS FILLED with OIL!

#### To check the oil level:

1. Always check the oil level when the air compressor is on flat and level ground.
2. To confirm the oil level lift the back, wheel end, up about 20cm, hold for about 1 minute and place back on ground.

Look at the sight glass and ensure the oil is above the red dot on the sight glass, as per the "OIL LEVEL GAUGE" label, see Pic. 3 and Pic. 4.

#### To add oil, if required, additional oil not included:

1. Remove oil breather.
2. Add oil, SAE30 to at least the top of the red dot, see Pic. 4.
3. Oil level will take about 1 minute to drain down and settle.
4. Check oil level in sight glass, see Pic. 3. Re-check and top up if required, until level is correct.

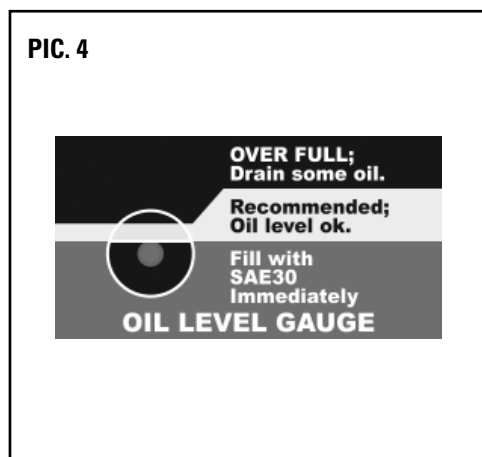
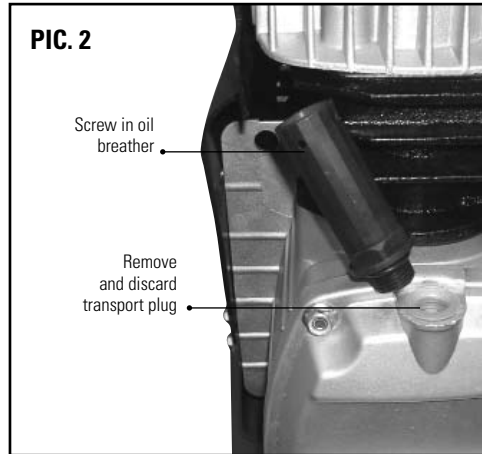

### WARNING

Do not attempt to operate this compressor until it is fully assembled.

Damage caused due to incomplete assembly will not be covered under warranty.

Ensure the air compressor is disconnected from the power supply before carrying out any assembly, maintenance or adjustments on the machine.

Never under fill or over fill with oil.

## RUBBER STOPPER

To attach the rubber stoppers to the bracket located on the bottom of the tank;

1. Undo the nut and remove the washers.
2. Push through the bracket and replace the washer.
3. Tighten the nut, Pic. 5.

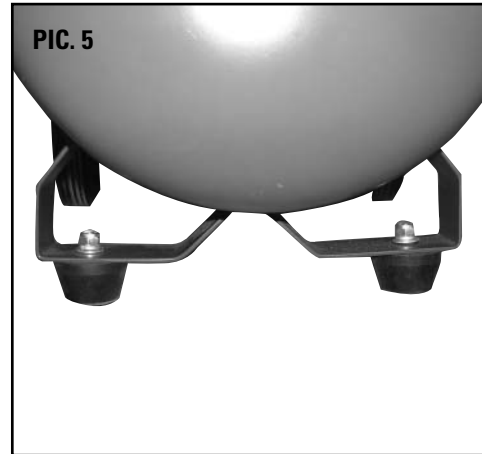

## WHEELS

1. Insert a bolt through the wheel.
2. Push through the tank wheel bracket.
3. Tighten the nut, Pic. 6.

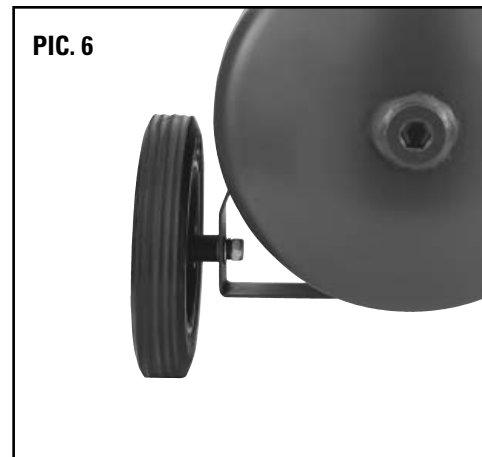

## HANDLE

1. Loosen bolts in tubes welded to the tank.
2. Push handle into tubes welded on the tank.
3. Tighten the bolts to hold handle in place, Pic. 7.

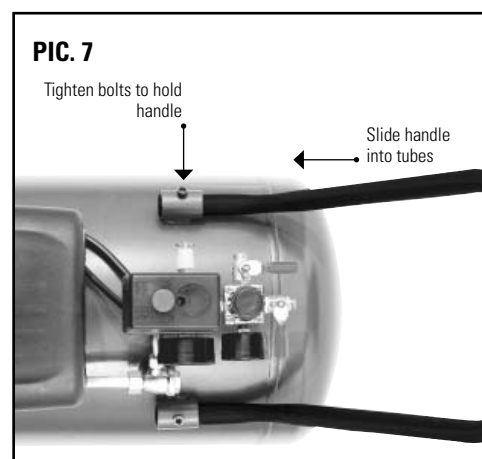

## AIR FILTER

The supplied air filter must be used.

Failure to do so may result in irreparable damage and will void the warranty, Pic. 8

### To install:

1. Carefully screw supplied air filter into the threaded hole on the top of the pump head. This only needs to be done up by hand. Do not use tools to tighten air filter.

NOTE: Do not OVER TIGHTEN as this may damage the air filter or cylinder head which will NOT be covered under warranty.

PIC. 8



## STARTING AND STOPPING YOUR AIR COMPRESSOR

### Pic. 9

NOTE: Always ensure that you plug your air compressor into a standard 240V AC power point. Never use an extension cord as this can lead to a voltage drop which may cause power loss and over heating. Use a longer air hose if you need to get closer to your work area.

Always start and stop the compressor using the ON/OFF button on the Pressure Switch (Pic. 1 Item 1 and 14 as well as Pic. 9). Damage caused by not using this button will not be covered by warranty.

### To turn your air compressor ON;

Lift up the red ON / OFF button on top of the pressure switch

### To turn your air compressor OFF;

Push down the red ON / OFF button on top of the pressure switch

PIC. 9

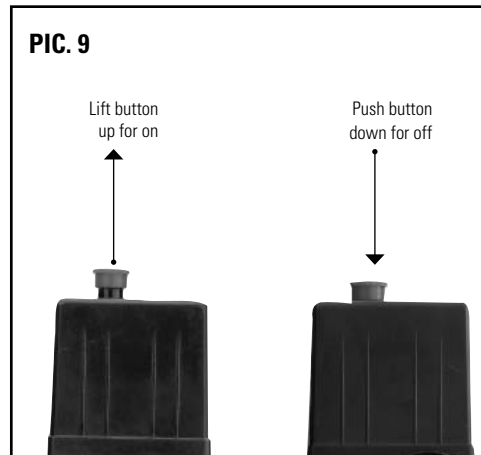

## RUNNING IN YOUR NEW AIR COMPRESSOR

### Before running in ensure that the following has been completed:

1. The transport plug has been removed and discarded, see pic. 2 page 10.
2. The oil breather has been fitted, see pic 4. page 10.
3. Oil level is correct, see page 10.
4. The air compressor has been fully assembled, see pages 10 – 12.

### Your new air compressor requires running in:

1. Plug the power cord into a standard 240V AC power point
2. Open the air tap
3. Open the tank drain tap
4. Start the air compressor using the ON / OFF button
5. Run the air compressor for approximately 1 minute

This ensures that the air compressor is fully lubricated under no load.

After the 1 minute stop the air compressor using the ON / OFF button. Allow to cool approximately 10 minutes. Recheck the oil level and top up if needed, additional oil, SAE30, not included.

### Before starting your air compressor again ensure:

1. Air tap is closed
2. Tank drain tap is closed

## USING THE AIR COMPRESSOR

### Before starting run through this simple list:

1. Transport plug removed and discarded, see Pic. 2, page 10.
2. Oil breather fitted, see Pic. 2, page 10.
3. Oil level – CORRECT (top of red dot). Please refer to diagram, Pic. 4, page 10.
4. Air tap – CLOSED
5. Drain tap – open and drain tank
6. Drain tap – close fully
7. Check power lead for any damage. If damaged have replaced by an authorised service centre.
8. Plug air compressor into a standard 240V 10Amp AC power point and turn ON.
9. Lift the air compressor red button to turn ON, see page 12, Pic. 9.
10. Allow the air compressor to fill the air tank.
11. Turn the air compressor OFF.
12. Turn the power point OFF and disconnect the power lead from the power point.
13. Connect your air hose and air tools.
14. Reconnect to the power lead to the power point and turn ON.
15. Turn your air compressor ON.
16. You begin using the connected air tools the air compressor will start and stop without warning. This is controlled by the pressure switch. These pressure settings are factory set and should not be changed.

Pumping starts at (minimum) 115PSI and stops at (maximum) 145PSI. Once the initial pump up stage has finished you can adjust the outlet air pressure to the tools recommended working pressure and open the air tap fully.

**NOTE! Maximum pressure is 10BAR (145PSI), check tool operating pressure before connecting and operating your air tool.**

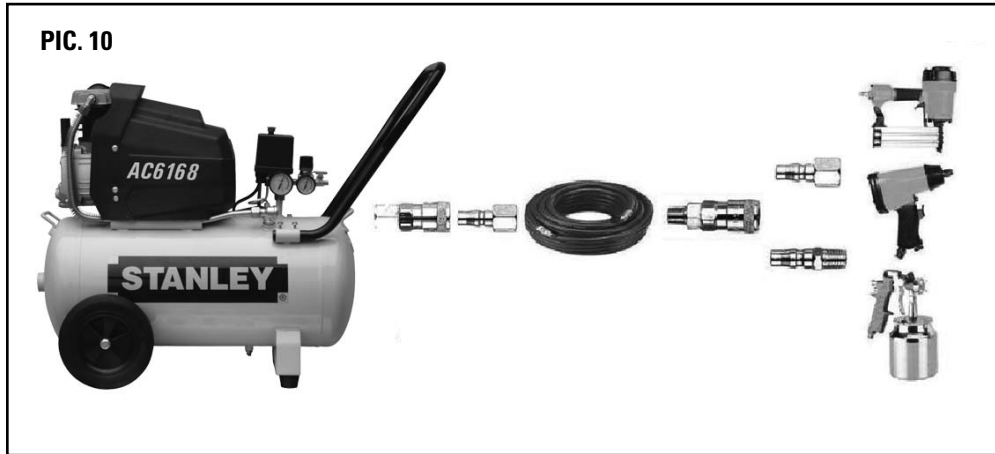

The configuration of tools and accessories can be varied to suit your particular requirements. A basic recommended set up is shown in Pic. 10 (accessories not included).

**When you have finished using your air compressor follow these simple steps:**

1. Turn your air compressor OFF, using the ON/OFF button.
2. Turn the power point OFF and disconnect the power lead.
3. Disconnect your air tools and air hose.
4. Clean your air hose and air tools.
5. Store your air hose and air tools in a secure well ventilated cabinet.
6. Slowly open the tank drain tap, see page 15. This allows excess air and moisture, water, to vent.
7. Leave the tank drain tap open. This allows any moisture to drain while the air compressor is stored.

## ADJUSTING THE PRESSURE

To adjust the outlet air pressure, use the red coloured regulator knob and check the pressure on the outlet pressure gauge, Pic. 11.

If the pressure needs to be lower, turn anti clockwise.

If the pressure needs to be higher, turn clockwise.

Use the gauge to ensure you set the correct working pressure.

Note: Different air tools require different operating pressures. Always check with the tool manufacturer if unsure.

**NOTE! Maximum pressure is 10BAR (145PSI). Check tool operating pressure before connecting and operating your air tools.**

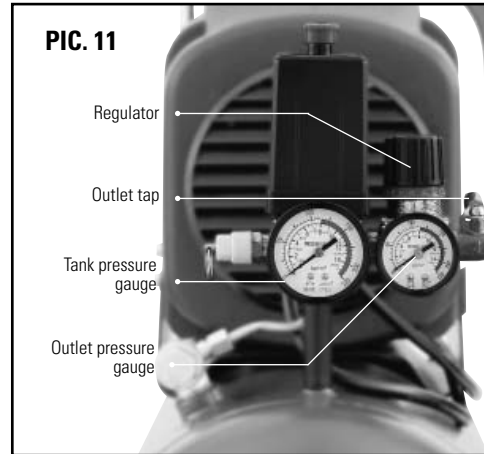

## SAFETY VALVE

### Pic. 12

NOTE: When checking the safety valve ALWAYS wear safety glasses.

To check the operation of the safety valve the air tank will need to be full. Gently pull the ring outwards. This should release air under pressure. Release the ring and this should stop the air out flow once the tank pressure has dropped.

If the safety valve does NOT work in this manner, STOP the air compressor immediately and have the air compressor checked / serviced by an authorised service centre.

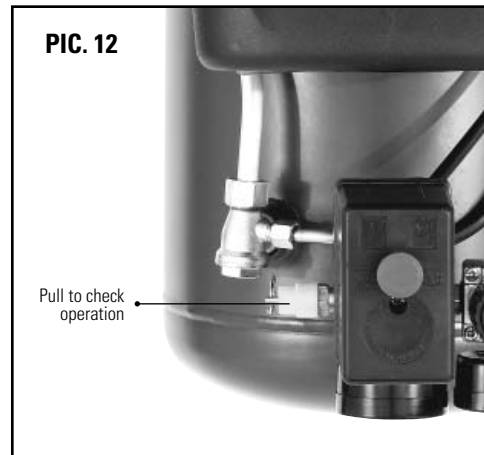

## AIR TAP

### Pic. 13

The air tap will need to be opened to allow the air to flow to the attached air tool.

To open air tap rotate the handle so that it lines up with the fittings and hose, not supplied.

To close air tap rotate the handle so that it is at 90° to the fittings and hose, not supplied.

**NOTE! This air compressor has a maximum pressure of 10BAR (145PSI), always regulate the air pressure to match your air tool. Different air tools require different operating pressures. Always check with the tool manufacturer if unsure.**

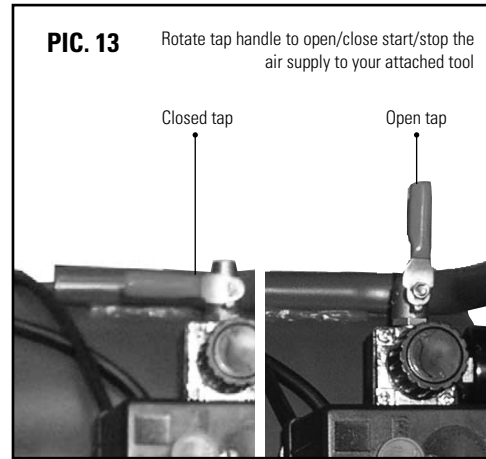

## DRAIN TAP

### Pic. 14

After use open the drain tap to drain excess air and any moisture. The excess air will also help purge the moisture. Leave the drain tap open when air compressor is not in use, so any moisture can continue to drain

To open the drain tap pull the lever down to vertical.

To seal the drain tap push the lever up to horizontal.

NOTE: Remember to seal the drain tap before starting the compressor.

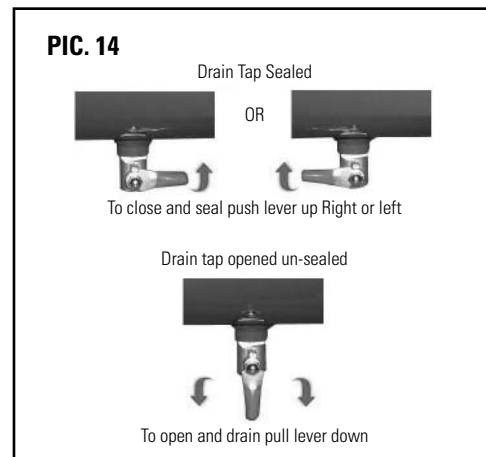



## MAINTENANCE

### Daily

#### Before use

1. Seal the tank drain tap, see Pic.14.
2. Check the oil level, see page 10, Pic. 4.
3. Check safety valve operation, see page 14, Pic. 12.

#### After use

1. Open the tank drain tap, see Pic.14.
2. Wipe down the air compressor.
3. Store safely and securely.

### Every 50 Hours

1. Replace the air filter.
2. Drain oil completely and replace with fresh oil  
To drain:
  - a. Loosen and remove the drain bolt, Pic. 15 and drain oil into a funnel / bottle and dispose of in an appropriate manner.
  - b. Once drained replace and tighten the drain bolt.
  - c. Wipe up any oil spills.
  - d. Fill up to the top red dot on the sight glass with fresh clean oil. Refer page 10 for "To Add Oil, if Required" details. Refer to diagram Pic. 4, page 10.

NOTE: Use oil type SAE30.

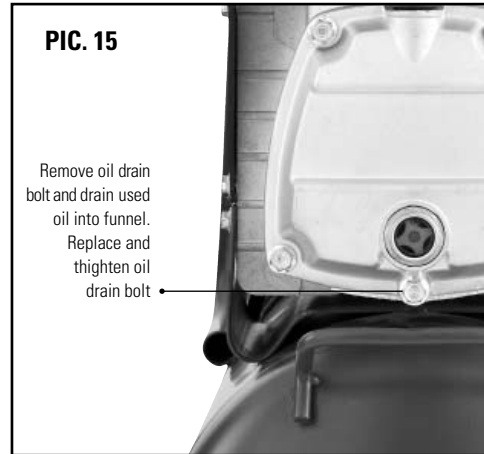

## TROUBLE SHOOTING

### If your compressor does not start

- Check that you have plugged the power lead into a standard 240V 10Amp power point and turned the switch ON.
- Check that you have turned the air compressor ON/OFF switch ON.
- The air tank may be full. Use your air tool and the air compressor should start when the pressure decreases to 115PSI.

### If your compressor does not build up pressure

- Check that the tank drain tap is sealed.
- Check that the air tap is closed.

### If your compressor smells like burnt oil

- Check the oil level as it may be low
- Compressor is being used beyond its 75% duty cycle. Allow to cool for 30 minutes before reusing compressor. Stay within the 75% duty cycle (refer to pages 5 and 8).

If these tips do not work please have your unit checked by an authorised service centre.

Call Smart Marketing Group for your closest centre,  
**Aust. 1300 660 457 N.Z. 0800 474 876.**

## PARTS DIAGRAM

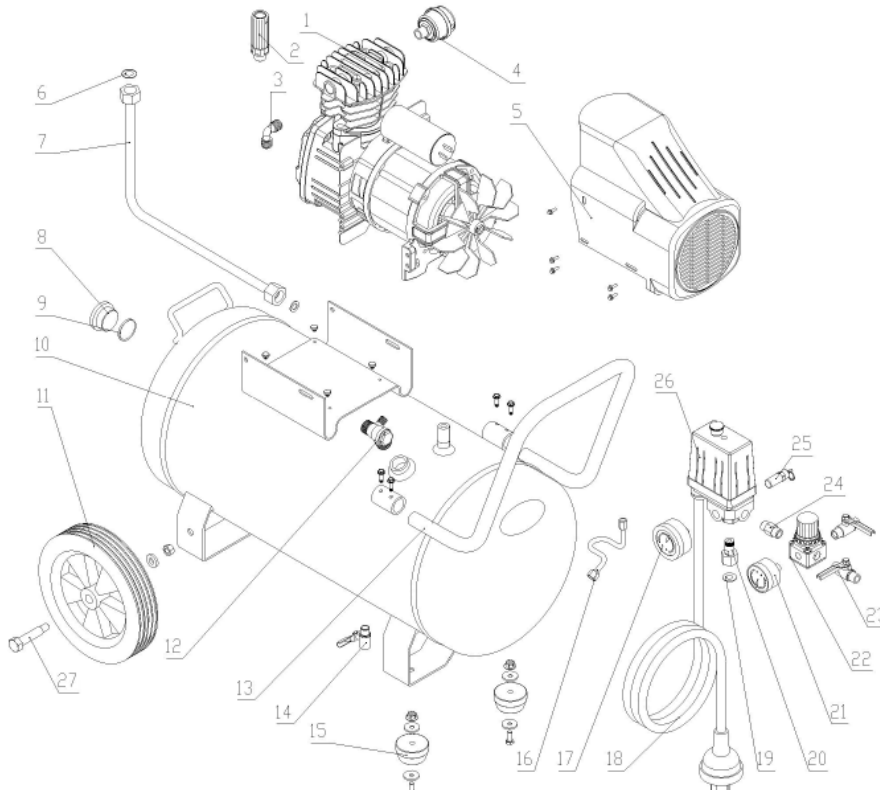

Part	Description	Qty	SMG Part No.
1	Cylinder Head	1	95 BRC95CH
2	Oil Breather	1	95 BRC95OB
	Sight Glass Seal	1	95 BRC95OLSG
	Sight Glass	1	95 BRC95OLSG
3	Exhaust Elbow	1	95 AC6168EE
4	Air Filter	1	95 BRC95AF
7	Exhaust Tube	1	95 AC6168ET
7	Exhaust Tube Nut	2	95 AC6168ET
11	Wheel	2	95 AC6168WH
12	One Way Valve	1	95 BRC950WV
13	Handle	1	95 AC6158TH
14	Drain Tap	1	95 BRC95DT
15	Cushion Foot	2	95 BRC95RS
15	Nut	2	95 BRC95RS

Part	Description	Qty	SMG Part No.
15	Washer	2	95 BRC95RS
15	Screw	2	95 BRC95RS
16	Unloading Tube Nut	2	95 AC6168UT
16	Unloading Tube	1	95 AC6168UT
17	Pressure Gauge Large	1	95 BRC95TPG
21	Pressure Gauge Small	1	95 BRC95OPG
22	Regulator Dual Tap	1	95 BRC1200PRD
23	Outlet Tap	2	95 BRC95OT
24	Connector	1	95 BRC95PTC
25	Safety Valve	1	95 AC6168SPV
26	Pressure Switch	1	95 BRC95PS
27	Bolt	2	95 BRC120WHB
27	Screw Nut	2	95 BRC120WHB

## TECHNICAL INFORMATION

Specifications	
Air Compressor	AC6168
Voltage	240V AC ~ 50Hz
Motor	Electric 2 ½ Hp
Wattage	1950W
No Load Speed	2800 RPM
Free Air Delivery (FAD)	155 L per minute*
Tank Size	40 L



## SUGGESTED APPLICATIONS

You may use most light duty air tools with this compressor.

Some examples of light duty tools are;

- Tyre Inflator
- Blow Gun
- Engine Cleaning Gun
- C Bradder
- T-Nailer
- Low Pressure Spray Gun
- Gravity Feed Spray Gun
- Air Hammer
- Sandblaster

This light duty air compressor is NOT recommended for use with a finishing spray gun or high pressure spray gun.

**For any queries or assistance call**



**Customer Service**

**AUST. 1300 660 457**

**NZ 0800 474 876**

Hours of operation:

Monday to Friday 8.30am - 5.00pm AEST

**Do not return to place of purchase.**

Keep your purchase receipt, this will be required to make any claims under the 2 year warranty.

STANLEY® is a registered trademark of Stanley Works and its subsidiaries.  
Manufactured under license by Smart Marketing Group Pty Ltd.

**STANLEY**

