



Value you can trust



## 4.3" WIRELESS REVERSING SYSTEM WITH BUTTERFLY CAMERA

*Owners/Instruction Manual*



PLU 373886

This wireless reversing camera system can be installed without the need to run wires through the vehicles passenger compartment, which can be difficult for some DIY installers. As the video signal is sent wirelessly, the time and difficulty of the installation is greatly reduced.

## Installation

### Monitor:

Find a suitable location for the monitor ensuring that your vision is not obstructed in any way. Connect the red wire to a 12V power source (+) and the black wire to a negative.

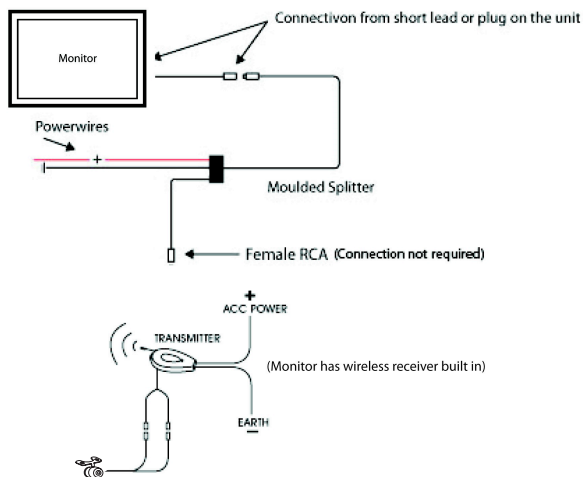

### Camera:

At the rear of the car locate a suitable mounting location for the butterfly camera ensuring that it is located as close to the center of the vehicle as possible and attach using screws. When mounting the camera, make sure the camera does not cover any part of the license plate. With the license plate removed, check if there are any pre-existing holes through which the cables from the camera can be passed through to the boot of the vehicle. Run the cables through the hole and re-attached the license plate.

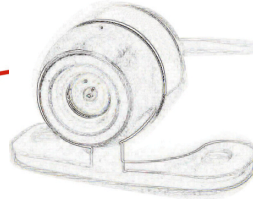

Installation example of stealth camera.

### Wireless connection:

1. Connect the RED wire of the wireless video transmitter to the wire that supplies power to the reversing light (this wire is energized when the vehicle is put into reverse gear). Measure the voltage on this wire to ensure it is +12V when energized. Use a suitable splicing/crimp connector (Scotch lock type) to connect the RED wire to the reversing light wire. Alternatively you can strip back the insulation on the wire and solder the connection making sure to insulate the connection with electrical tape or heat shrink tubing after the join is made.
2. Connect the black wire of the transmitter to a suitable ground such as the metal body of the vehicle. Attach an "O" ring terminal at the end of the black wire, and secure the wire to the vehicles chassis.
3. Plug the RCA and power connections of the transmitter cable into the corresponding sockets of the camera harness.

**NOTE:** Some cars that run LED or computer controlled lighting systems may not deliver enough voltage to run the transmitter. If the voltage at the reversing light is less than +11 volts, it may be necessary to use a relay to supply power to the transmitter. In this case, the reversing light is only required to trigger the relay.

### Testing the Reversing Camera

1. Engage the vehicles park brake and switch the ignition key in the ON position. **DO NOT** start the vehicle.
2. Select the reverse gear with the gear shift.

The monitor will sense the video signal from the camera and automatically switch on. When switched on the screen will display an image of the rear of the vehicle.

In the event that you live in an area where RF interference is a problem (EG: Poor video signal) you may need to change to a wired solution using an RCA cable (Not included)

# 4.3" WIRELESS REVERSING SYSTEM WITH BUTTERFLY CAMERA

---

## *Warranty*

This product is guaranteed against defects for a period of 12 months from date of purchase. This warranty is provided by Super Cheap Auto Pty Ltd ACN 085 395 124 (Supercheap Auto) of 751 Gympie Rd Lawnton QLD 4501. Ph (07) 3482 7500. Supercheap Auto will offer a repair, replacement product or store credit if the product is assessed as being defective during the warranty period. To claim under this warranty, take this product to the Front Service Desk of your nearest Supercheap Auto store. For store locations, visit [www.supercheapauto.com.au](http://www.supercheapauto.com.au) (AUS) or [www.supercheapauto.co.nz](http://www.supercheapauto.co.nz) (NZ). You will need your receipt or proof of purchase. Additional information may be requested of you to process your claim. Should you not be able to provide proof of purchase with a receipt or a bank statement, identification showing your name, address and signature may be required to process your claim. This product may need to be sent to the manufacturer to assess the defect before determining any claim. Faults or defects caused by product modification, misuse and abuse, normal wear and tear or failure to follow user instructions are not covered under this warranty. Our goods come with guarantees that cannot be excluded under the Australian Consumer Law. You are entitled to a replacement or refund for a major failure and for compensation for any other reasonably foreseeable loss or damage. You are also entitled to have the goods repaired or replaced if the goods fail to be of acceptable quality and the failure does not amount to a major failure. Any expenses incurred relating to the return of this product to store will normally have to be paid by you. For more information contact your nearest Supercheap Auto store. The benefits to the consumer given by this warranty are in addition to other rights and remedies of the Australian Consumer Law in relation to the goods and services to which this warranty relates.

